

# FEEDER series

F A S T E N I N G I N N O V A T I O N  
f o r T H E F U T U R E



DF200



FF311DR



FF503H



FF801H

# Entrust your parts feeding to NITTO SEIKO!

NITTO SEIKO supplies 4 models of 3 different parts feeder types: disk type, drum (rotary cylinder) type and centerboard type. Their cost and noise level are lower and the required installation space is smaller compared with the other parts feeders.

More than 50,000 feeders have been sold in Japan and overseas since they were introduced into the market.

Utilizing that accumulated expertise and experience, we can feed any part with confidence.

NITTO SEIKO, a leading company in the field of screws and screw fastening machines, meets all of your feeding needs, which is indispensable for manufacturing and assembly line simplification.

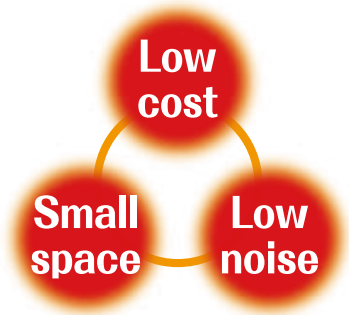

## Product lineup



DF200

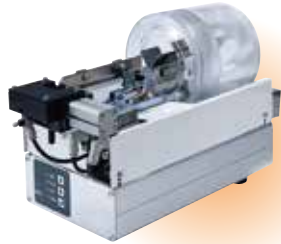

FF311DR



FF503H



FF801H

## Model selection graph



The following ratio is used as the rough evaluation criterion of normally fed screws:

$$dk/d=1.7\sim 2.1$$

If the ratio is outside of the limits, feeding capacity might be lower or screws might stagnate. In such a case, contact us.

If dimension L is extremely longer or shorter than dimension dk, similar troubles might occur.

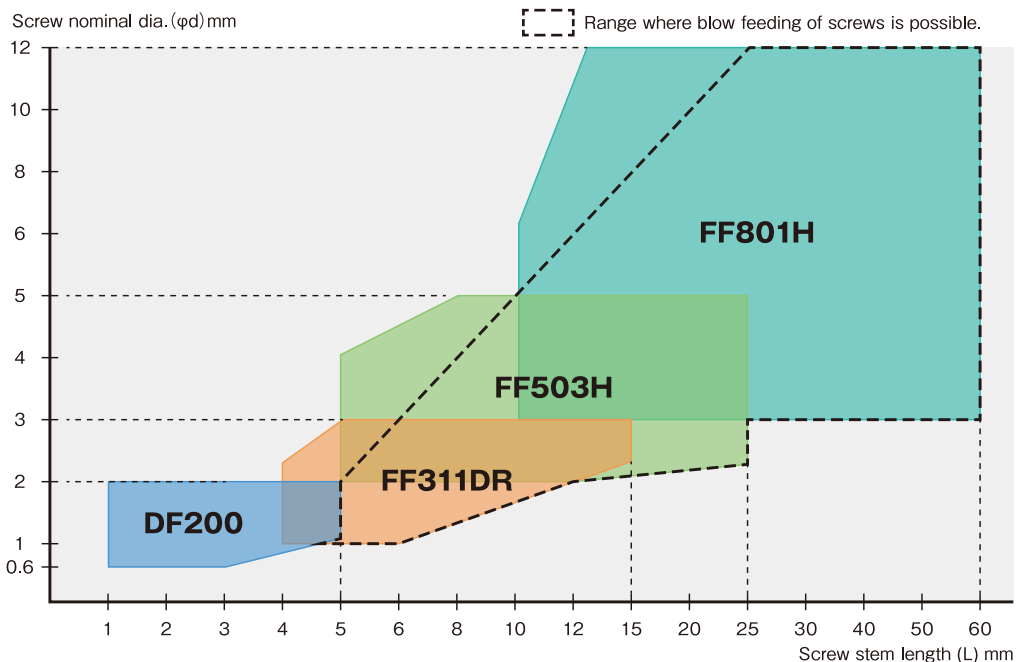

## Screw capacity calculation formula

$$\text{Estimated screw capacity } N = \frac{\text{Basket capacity (ml)}}{\text{Estimated screw volume} \left[ \frac{\pi dk^2 (L+K)}{4} \right]} \times \text{Coefficient (0.9)}$$

dk: Screw head dia. (cm), L: Screw stem length (cm), K: Screw head height (cm), d: Screw nominal dia.

●Simplified formula ※Figures in pink show the basket capacities.

$$\text{DF200} = \{ 50 \div (0.785 \times dk^2 \times (L+k)) \} \times 0.9$$

$$\text{FF311DR} = \{ 120 \div (0.785 \times dk^2 \times (L+k)) \} \times 0.9$$

$$\text{FF503H} = \{ 450 \div (0.785 \times dk^2 \times (L+k)) \} \times 0.9$$

$$\text{FF801H} = \{ 2000 \div (0.785 \times dk^2 \times (L+k)) \} \times 0.9$$

Example: FF503H for M3×10 pan head screws: The head height is 2 mm. The length is therefore 12 mm and the head dia., 5.5 mm. ... {450 ÷ (0.785 × 0.55² × 1.2)} × 0.9 = 1421 (approx. 1400 pcs.)

## Solution for Precision and Micro Screws

Simple mechanism which is using rotary disk system.  
High efficiency is achieved because of very low incidence of jamming.



### Precision screw/micro screw feeding

0.6 mm dia., flat head, short length, micro screw, and other screws with captive washers can be fed.

### Easy operation

Disk can be changed to feed different diameter screws. No other adjustments are required. Any screw with the same shaft diameter, no matter head-type or thread type, can be fed with the same disk.

### Installation in automatic lines

Efficient feeding prevents line stoppage due to feed faults. Efficient screw feeding prevents line stoppage due to screw feeding fault. External I/O signals can also be used.

### 【 Specifications 】

Model number		DF200
Applicable screws (Note 1)	Nominal dia.	0.6~2mm
	Length	max.5mm
	Head dia.	max.5mm
Screw feeding capacity (Note 2)	max. 25pcs./min.	
Basket capacity	Approx. 50mL	
External I/O	Input	Standard Interlock for rotation, Start rotation Optional _____
	Output	Standard Ready for pick-up, screw shortage and faults Optional _____
	Specifications	Input common 24VDC, 5mA, output common 0VDC, open collector output 40VDC (max.), 160mA
Memory	Flash memory	
Power supply (Note 3)	1φ 100VAC, 120VAC, 200VAC, 220VAC 50/60Hz	
Power capacity	max.50VA	
Adjustable details	Screw detection (adjustment using a pressure switch)	
Working air pressure	0.4~0.5MPa	
Air capacity (Note 4)	0.91L/cycle <ANR>	
Paint color	_____	
Machine weight	Approx. 4.5kg	

Note 1: Products will be built up based on specification of screws, therefore it can be used for one kind of screws only. Application range of screws will be changed by type of screw head, or size. Please contact us to make sure for it. Note 2: Varying depending on the screw type. For more information, contact us. Note 3: Must be selected at the time of order. Note 4: Varying depending on the feeder model.

### 【 Application example 】



● Screw Driving Robot equipped with 2 DF200 units

### 【 Outside dimension 】

Unit:mm

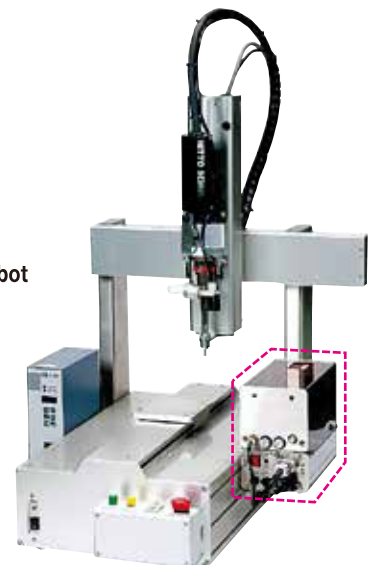
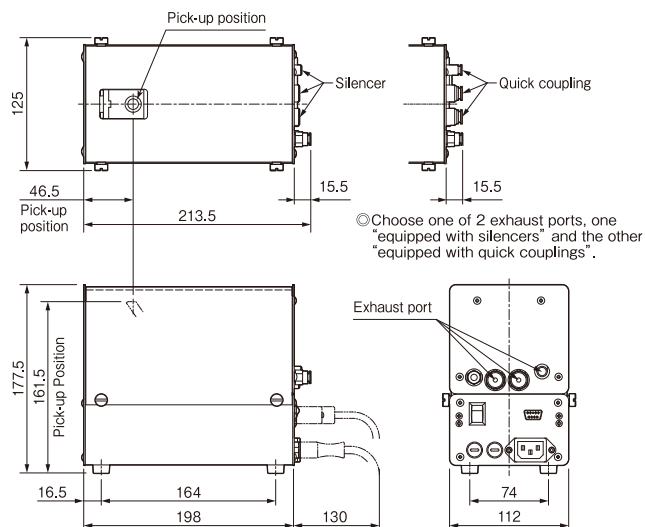

● Tabletop Screw Driving Robot equipped with the DF200

Example of machine configuration.

Disk type

Drum type

Centerboard type

Straight feed type

Pick-up type

Pressure feed type

Hopper type

# Compact Drum Type Screw Feeder **FF311DR**

## The solution for screws with captive springs and plain washers

A simple mechanism that lines up screws on the chute rail, clears screw jamming and stuck screws. This model is recommended if you use screws with captive springs and plain washers in PCB assembly.

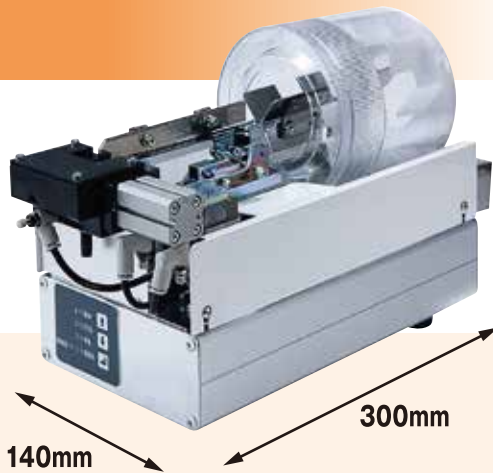

**Screws with captive springs and plain washers rarely jam.**



**Easy operation**  
Removable drum makes supplying screws easy.

### Compact body

Approx. 2/3 of A4 size. Body can be placed almost anywhere and can downsize the production line.

### 【 Specifications 】

Model number		FF311DR	
Applicable screws <small>(Note 1)</small>	Nominal dia.	1.2~3.0mm	
	Length	max.14mm	
	Head dia.	max.9mm	
Screw feeding capacity <small>(Note 2)</small>	max. 30pcs./min.		
Basket capacity	Approx. 120mL		
External I/O	Input	Standard	Screw feed command (for the automatic spec. only)
		Optional	Operation permission (for the screw pick-up spec. only)
	Output	Standard	Low screw on chute rail (for the automatic spec. only)
		Optional	Ready for pick-up (for the screw pick-up spec. only)
Specifications	SINK (NPN) spec. or SOURCE (PNP) spec. <small>(Note 4)</small>		
Memory	Flash memory		
Power supply	1Φ 100VAC~240VAC, 50/60Hz		
Power capacity	max.50VA		
Adjustable details	Timing to output the low screw on the rail signal, screw feeding time, etc.		
Working air pressure	0.4~0.5MPa		
Air capacity <small>(Note 3)</small>	1.4L/cycle <ANR>		
Paint color			
Machine weight	Approx. 5.4kg		

Note 1: Products will be built up based on specification of screws, therefore it can be used for one kind of screws only. Application range of screws will be changed by type of screw head, or size. Please contact us to make sure for it. Note 2: Varying depending on the screw type.

Note 3: Varying depending on the feeder model. Note 4: Must be selected at the time of order.

### Applicable Chute Rails

Use the chute rail which is most suitable for the screw (one of the 2 types) for optimal performance.

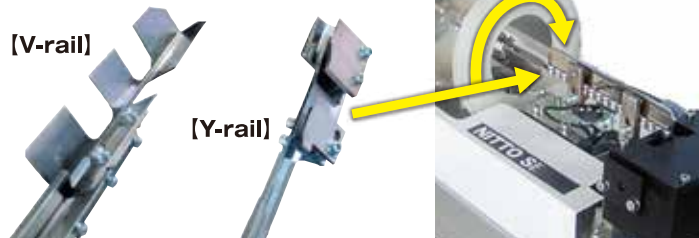

### 【 Application example 】

● Multi Spindle Screw Driving Machine using the FF311DR

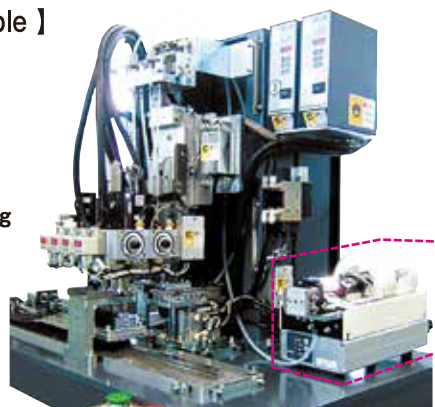

● Screw Driving Robot using the FF311DR

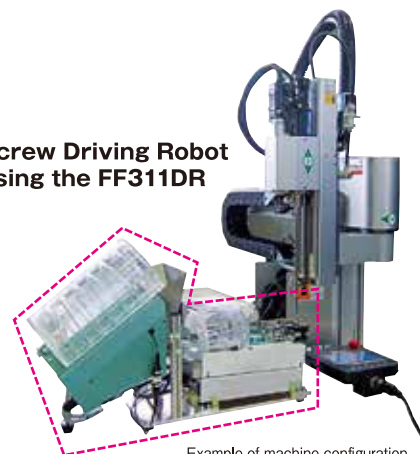

Example of machine configuration.

### 【 Outside dimension 】

Unit:mm

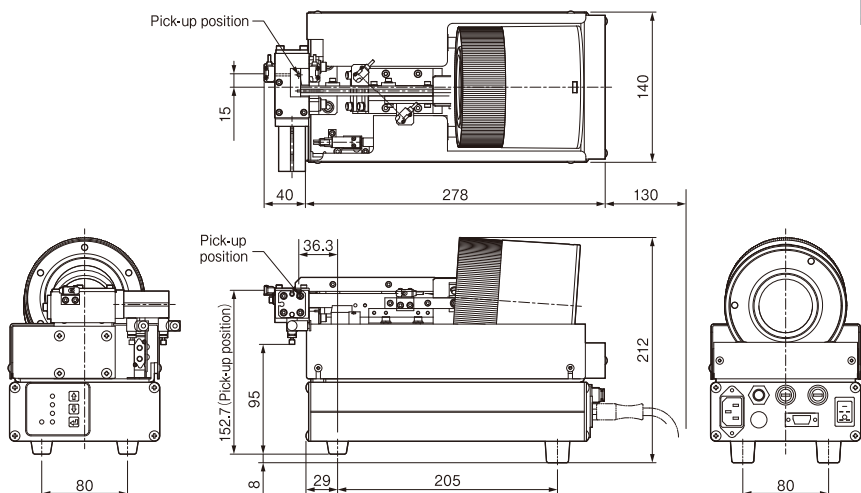

Disk type

Drum type

Centerboard type

Straight feed type

Pick-up type

Pressure feed type

Hopper type

## Higher-quality screw feeding!

Rivets, nuts, pins, steel balls, etc., can also be fed as well as screws and bolts. The compact body design enables installation almost anywhere and easy repositioning.



### Screw-friendly centerboard hopper

The vertically driven track scoops and lines up screws. Price and noise are lower compared with oscillating bowl feeders. Very mild on screws and coatings.



Oscillation feeds screws to the feeder end.



FF503H



FF801H

### Quickly Blow Feed Screws

Singulate screws and feed by air.  
※Dual escapement to feed two screws at once is available.



### Horizontal linear feeding for screws minimizes jamming.

## 【 Specifications 】

【 】: Optional

Model number		FF503H	FF801H
Applicable screws (Note 1)	Nominal dia.	2~5mm	3~8mm
	Length	max.25mm	max. 30mm, [50mm]
	Head dia.	max.12mm	max.17mm
Screw feeding capacity (Note 2)		Single escapement: max. 30pcs./min., Dual escapement: max. 50pcs./min.	Single escapement: max. 20pcs./min., Dual escapement: max. 40pcs./min.
Basket capacity		Approx. 450mL	Approx. 2000mL
External I/O	Input	Standard	Screw feed command (for the automatic spec. only)
		Optional	Operation permission (for the screw pick-up spec. only)
	Output	Standard	Low screw on chute rail (for the automatic spec. only)
		Optional	Low screw in basket (for the screw pick-up spec. only)
Specifications	SINK (NPN) spec. or SOURCE (PNP) spec. (Note 4)	Screw feed command (Multi-input) (Note 5) Low screw on rail (Relay contact)	
Memory		Flash memory	
Power supply		1φ 100VAC~240VAC, 50/60Hz	1φ 100VAC, 50 or 60Hz, [others than 100V]
Power capacity		max.50VA	max.100VA
Adjustable details		Straight feeding feeder oscillation frequency and amplitude, hopper oscillation speed, timing to output the low screws on rail signal, screw feeding time, etc.	Screw feed time and straight feeding feeder amplitude
Working air pressure		0.4~0.5MPa	0.4~0.5MPa
Air capacity (Note 3)		1.7L/cycle <ANR>	5L/cycle <ANR>
Paint color		Hammertone blue	Hammertone blue
Machine weight		Approx. 18kg	Approx. 50kg

Note 1: Products will be built up based on specification of screws, therefore it can be used for one kind of screws only. Application range of screws will be changed by type of screw head, or size. Please contact us to make sure for it. Note 2: Varying depending on the screw type. Note 3: Varying depending on the feeder model.  
Note 4: Must be selected at the time of order. Note 5: AC/DC multi-input 24V~100V.

**Counter function** (optional for the FF503H) +1

The part counter enables a designated number to be escaped.

**Sorter unit (Optional)**

The sorter unit enables various screw feeding.

**Dual Escapement**

Approx. 50 screws/min. of feeding is available.

## 【 Outside dimension 】 Unit:mm

### FF503H

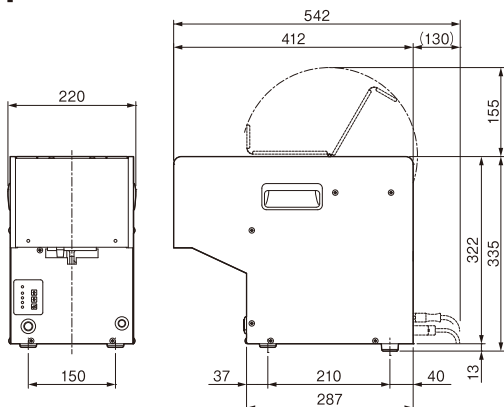

### FF801H

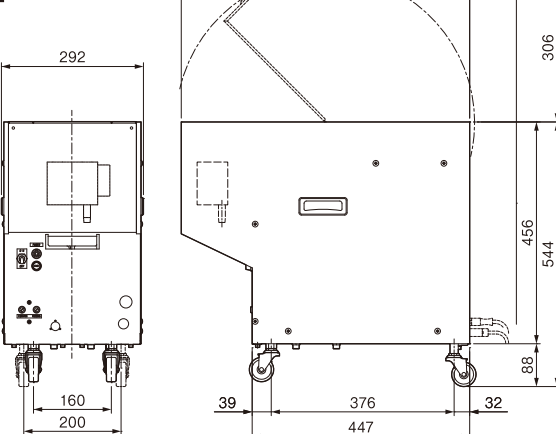

## 【 Application example 】

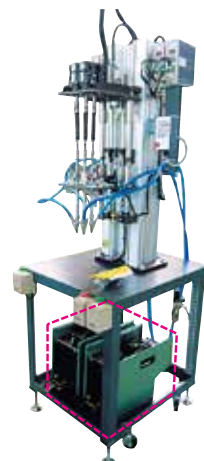

● Multi Spindle Screw Driving Machine equipped with 2 FF503H units

Example of machine configuration.

- Disk type
- Drum type
- Centerboard type
- Straight feed type
- Pick-up type
- Pressure feed type
- Hopper type



## Auxiliary hopper for less frequent screw filling (Optional)

### Separate installation space is not needed.

The hopper is directly mounted on the screw feeder and does not need as much installation space needed by a conventional auxiliary hopper.

**Easy screw filling** The barrel is removable.

### Low noise

The motor-driven hopper generates very low running noise.

### Easy mounting and dismounting

The hopper is a hanger type and can be easily mounted and dismounted.

### 【 Specifications 】

Model number	SH200	SH300
Hopper capacity	Approx. 2000mL	
Power supply	AC100V 50/60Hz	24VDC(from feeder: FF/FM503H)
Drive source	Induction motor	Stepping motor
Hopper action detection	Proximity switch	
Paint color	Hammerstone blue	
Machine weight	Approx. 4.5kg	
Applicable feeder model	FF801H	FF311DR, FF503H

Note 1: Screw length is 30mm or less and nominal dia., M2-M5.

#### Basket level sensor is standard

Constant screw level maintained in main feeder basket.



#### Drop prevention chute(Optional)

Prevents screws from dropping out of the feeder while screws are supplied.



plus  
+1

### 【 Outside dimension 】 Unit:mm

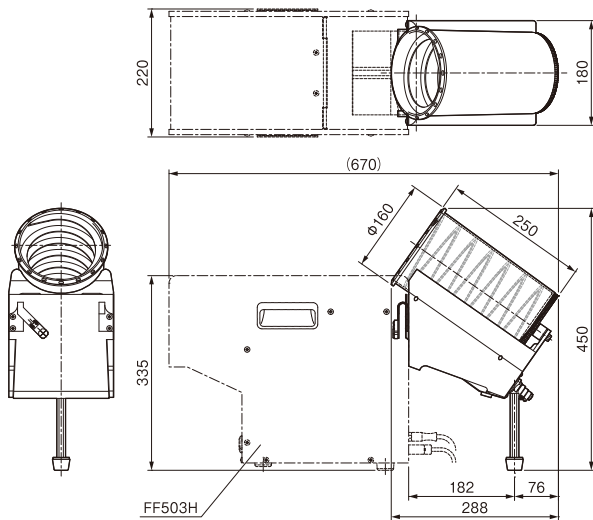

### 【 Application example 】

#### ●FF311DR+SH300

The hopper is mounted on the FF311DR top or rear in accordance with the mounting space.



#### ●FF503H+SH300



#### ●FF801H+Auxiliary hopper

※Hopper capacity is 5L or 30L.



## FEEDMAT Handheld screw driving tool

Handheld FEEDMAT types comprising feeders and fastening units are also available.



FM311DR-BL



FM503H-BL



FM503H



FM801H

※For more information, see our website or contact the nearest sales office.

## NITTOSEIKO CO.,LTD.

Assembly Machine Division / Shiroyama Plant  
Global Sales Section

2,Shiroyama-chou,Ayabe-city,Kyoto 623-0003,Japan  
TEL:+81-773-42-1290 FAX:+81-773-45-3680  
URL:<https://www.nittoseiko.co.jp/en.html>

●Specifications and other matters are subject to modifications for performance improvements without notice.  
●Unique nouns like the product name indicated in this brochure are registered or not registered trademark of each company.