

## Digital Flow Rate Indicator &amp; Totalizer MC82

## Specification

SSF10551 25.07

### ■Outline

This equipment converts from voltage to frequency (V/F) and indicates momentary flow rate and integrated total flow.

And also, it outputs pulse signal synchronized with indicated integrated total flow.

### ■Features

- Available for changing indication of momentary flow rate and integrated total flow by pressing the  $\boxed{S}$  key or by switch signal input.
- Available for analog signal output, comparative output and also communication function as an option.
- RS-485 communication as an option can read Integrated total flow, momentary flow rate, indicating value, comparative output value, indication state, and comparative output state, as well can write comparative output value.
- Unique method or Modbus-RTU is applied for communication protocol.
- It can show integrated total flow, momentary flow rate, or indicating value onto our large indicator without programming.

### ■Specifications

**Analog input Kind** Select from current input or voltage input

● Direct current input

Input signal 4~20mADC, 0~20mADC  
Input resistance 10 $\Omega$

● Direct voltage input

Input signal 1~5VDC, 0~5VDC, 0~10VDC  
Input resistance 1M $\Omega$

#### Flow measurement

Method Voltage to Frequency conversion  
Sampling Freq. 20ms  
Low cut OFF at 0.01~50.00% of full scale.  
0 flow judgment time at OFF setting:  
Approx.1sec

Accuracy  $\pm 0.2\%$  of full scale  $\pm 1$  digit  
(In case of 23°C $\pm 5^\circ$ C  
Temp. factor:  $\pm 150$ ppm/ $^\circ$ C)

Warm-up period 10 min

#### Flow indication

Display 7 segment red LED  
7.9W $\times$ 14.2H 6 digits  
Zero suppression  
Decimal point Available for setting the point  
Display switch Switch indication momentary flow rate or integrated total flow by pressing  $\boxed{S}$  key or switch signal input.

Flow rate/ Total flow light Red LED 2.8W $\times$ 1H



#### Momentary flow rate indication

Indication up-date cycle 0.1/ 0.2/ 0.5/ 1~10s  
(STD. Approx. 1sec)  
Moving average 1~20 times  
Fixed indication OFF, 5, 10, 100  
Number of digits 4 digits  
Indication unit /h, /min, /s

#### Integrated total flow indication

Initial value Available for setting the value at reset  
Over flow Stop at 999999 and blink, or start from 0

#### Reset

#### Operation

Manual reset Reset total flow by pressing  $\boxed{M}$  and  $\boxed{S}$  key simultaneously while indicating total flow

Remote reset input (resettable when indicating flow rate or total flow)

Kind of signal no-voltage contact signal or open collector signal  
Signal width 20ms and longer  
Voltage/Current Approx. 12V  
Approx. 8mA

#### Switch signal input Action

Select the action from "Indication switch", "Prohibition" or "Hold"  
Kind of signal no-voltage contact signal or open collector signal  
Delay time Approx. 20ms  
Voltage/Current Approx. 12V / Approx 8mA  
Switch signal input light Red LED 1.5 $\phi$

#### Analog output (OPTION)

Signal contents Select from momentary flow rate or integrated total flow  
Output signal Select from Voltage output or Current output  
Voltage : 1~5V, 0~5V, 0~10VDC  
Current : 4~20mADC

#### Allowable load resistance

1~5V, 0~5V : 1k $\Omega$  and more  
0~10V : 2k $\Omega$  and more  
4~20mA : 500k $\Omega$  or less

	Warm-up period	15min	Parity	Without / Odd number / Even number
	Conversion method	DA method	Stop bit	1bit / 2 bit
	Resolution	Approx. 1/40000	Transmission control	Reply type / Continuous transmission
	Conversion speed	Approx. 42ms	Error check	BCC check sum
	Conversion accuracy	±0.15% of full scale (at 23°C±5°C Temp. factor : ±150ppm/°C)	Communication Contents	
<b>Pulse output</b>	Signal contents	Unit pulse	Read	Indication value, Setting value of comparative, Setting value of upper and lower limit for analog signal, Initial value of integrated total value, Condition of indication, Condition of comparative output, Momentary flow rate, Integrated total flow value.
	Kind of signal	select from 12V no-contact or open collector	Write	Setting value of comparative, setting value of upper and lower limit for analog signal, Initial value of integrated total value
	Signal logic	Select from positive or negative		
	Signal width	0.01~2s by parameter setting		
	Frequency	25Hz or less		
	●12V no-contact signal output			
	Signal level	H : Approx. 10V (at no load) L : 0.5V or less (at no load)		
	Output resistance	Approx. 1.5kΩ		
	●Open collector output			
	Voltage / Current	30V DC / 20mA		
Voltage at ON	0.5V or less			
<b>Comparative output (Option)</b>			<b>Power failure storage</b>	
Output point	2 points		Type of storage	EEPROM
Signal contents	Select from momentary flow rate or integrated total flow		<b>Power source for generator</b>	24V DC ±10% 80mA (STD) 12V DC ±10% 100mA (OPTION)
Setting	Switch the indication and show setting value on the 6 digits display.		<b>Insurance resistance</b>	500V DC 100MΩ or more Between respective terminal block of Input, comparative output, analog output, communication, and power source. 0 V and 2 <sup>nd</sup> 3 <sup>rd</sup> 14 <sup>th</sup> terminal block is common
Output configuration	Select from upper limit or lower limit		<b>Withstand voltage</b>	2,000V AC 1 minute Test point: Power source terminal 7 <sup>th</sup> and 8 <sup>th</sup> collectively, input terminal 1 <sup>st</sup> 2 <sup>nd</sup> 3 <sup>rd</sup> 4 <sup>th</sup> 5 <sup>th</sup> 6 <sup>th</sup> 14 <sup>th</sup> 15 <sup>th</sup> collectively, and comparative output terminal 9 <sup>th</sup> 16 <sup>th</sup> 17 <sup>th</sup> 18 <sup>th</sup> collectively.
Output performance	Select from one of comparative output, output holding or one-shot output		<b>Noise resistance</b>	Square wave noise by noise simulator 1,500 V (Noise width 1μs, Polarity ±, Synchronous application of power source, Phase 0~360°)
Hysteresis	2~9999digit		<b>Power source</b>	85 ~ 264 V AC 50/60Hz (AC power type) 11~48 V DC (Ripple 5% or less) (DC power type)
Prohibition at power ON	Prohibit output lower limit or output for a while (0.1~99.9s) when turn on a power.		<b>Power consumption</b>	Approx. 10VA (AC power type) Approx. 6W (DC power type)
Response time	Approx. 52ms		<b>Ambient temperature</b>	0~50°C (Without freezing)
Kind of signal	No-voltage contact		<b>Ambient humidity</b>	45 ~ 85 % RH (Without dew condensation)
Contact capacity	250V AC 0.5A / 30V DC 1A (Load resistance)		<b>Weight</b>	Approx. 0.3kg
Comparative output light	Red LED 2.8W×1H		<b>Casing</b>	Body: ABS Plastic Front: ABS / Acrylic Plastic
<b>Communication function (Option)</b>			<b>Protection structure</b>	IP65 (Front panel)
Standard	EIA RS-485			
Method	2 wire half-duplex			
Synchronization	Asynchronous			
No. of connection	32 equipment include upper computer (host computer)			
Unit No.	00~99			
Delay time	Select from 10~500ms (Error 10ms or less)			
Speed	1200/ 2400/ 4800/ 9600/ 19.2k/ 38.4kbps			
Transmission code	ASCII code			
Data length	7b bit / 8 bit			

■ External dimension and panel cut dimension

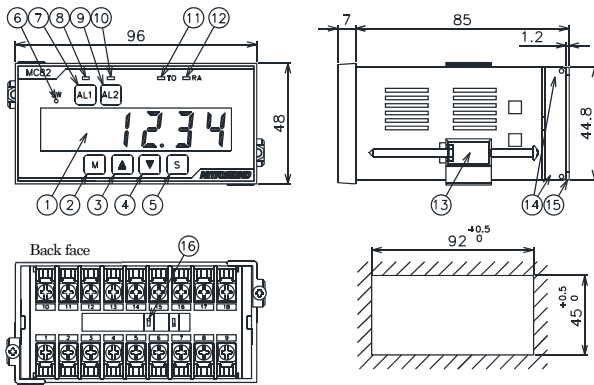

No.	Name
1	Flow rate display
2	[M] (Mode) key
3	[▲] (Up) key
4	[▼] (Down) key
5	[S] (Set) key
6	Switch input light
7	[AL1] key (For comparative output only)
8	AL1 light (For comparative output only)
9	[AL2] key (For comparative output only)
10	AL2 light (For comparative output only)
11	Integrated total flow light
12	Momentary flow rate light
13	Mounting fixture
14	Terminal block
15	Terminal cover
16	Setting switch (SSW)

■ Operation

■ Power activation

- When power is activated, momentary flow rate or integrated total flow is shown depending on the setting of parameter. In case of integrated total flow, total value before turning off of power is appeared.

■ Flow measurement

- Converts from voltage to frequency (V/F) and indicates momentary flow rate and integrated total flow.
- It shows flow rate as 0 when the flow rate is lower than the setting value of low cut. It does not add integrated total flow, and does not output pulse signal. In case of setting OFF of low-cut function, 0 flow judgment time is Approx. 1sec.

■ Flow indication

- Display shows momentary flow rate or integrated total flow value. "Switching indication of momentary flow rate and integrated total flow value", "Momentary flow rate only", or "Integrated total flow value only" can be set by parameter setting.
- [S] key or Switch input (required indication change setting) makes display switched momentary flow rate indication and integrated total flow value.
- Momentary flow rate indication is update in each indication frequency. Indication frequency can be set by parameter setting.
- By setting parameter for number of moving average at each indication frequency, response speed will be slow, but flow rate indication will be stabilized.

- Parameter setting as multiply number of 5, 10, or 100 indication makes subordinate digits fixed 5, 0 or 00.
- Pressing [M] key and [S] key at same time reset integrated total value when indicating integrated total flow. Remote reset signal input can reset integrated total flow value when indicating momentary flow rate or integrated total flow value.
- When integrated total value is overflow, available for select by parameter setting from "blinking indication 999999" or "counting from 0 again".

■ Switch input

- By parameter setting, Indication change, Prohibition, or hold operation is selected.
- In case of using as indication switch, ON indicates integrated total flow value, and OFF indicates momentary flow rate.
- In case of using as prohibition, ON makes same operation as without analog signal.
- In case of using hold operation, ON makes indication holding.

■ Pulse output

- Output unit pulse signal synchronized with indicated integrated total value.
- It can select from which digits unit pulse output by parameter setting.
- Kind of signal and signal logic are selected by switch setting.
- Signal width is set by parameter setting
- Switch setting

Setting Switch SSW

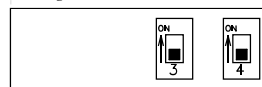

SSW	3	4
ON/OFF	Kind	Logic
ON (UP)	12V No-contact	Negative
OFF(DOWN)	Open collector	Positive

■ Analog output (Option)

- Analog signal output can be select from among 4~20mA DC, 1~5V DC, 0~5V DC, or 0~10V DC.
- Output momentary flow rate or output integrated total flow value is set by parameter setting.
- Update momentary flow rate at each sampling period or update synchronized with momentary flow rate is selected by parameter setting.

■ Comparative output (Option)

- Comparison content is selected by parameter setting from momentary flow rate or integrated total flow.
- Upper limit operation or lower limit operation is selected by parameter setting.
- Continuous comparative operation, hold operation (for momentary flow rate only), or one-shot operation is selected by parameter setting.
- Hysteresis of momentary flow rate, prohibition of lower limit operation of momentary flow rate at power ON, and output delay are available.
- Hold operation awakes by reset.

■ Communication (Option)

For the detail, please refer the instruction manual.

• Communication contents by RS-485 are as follows.

- (1) Reading of Integrated total volume, momentary flow rate and indicating value
- (2) Reading of comparative output value, indication state, and comparative output state
- (3) Writing of comparative output value

• Momentary flow rate, integrated total value, and indicating value can be shown largely on the remote place by connecting to our large indicator DH1 or DS1. MC82 becomes primary and large indicator becomes replica.

It can connect up to 4 equipment as replicas.

When connect 2 large indicators, integrated total volume and momentary flow rate are shown respectively. One of the replica is main-channel, and the other is sub-channel. Communication between primary and replica is by our unique method. Showing contents is set by parameter of large indicator.

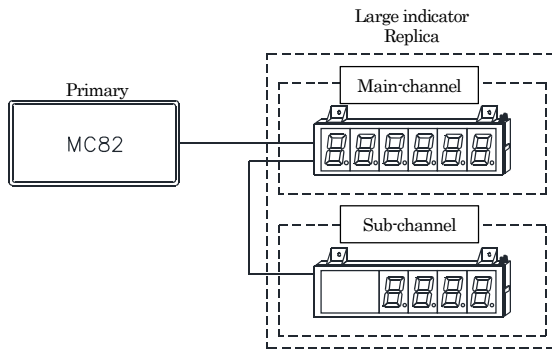

■ Terminal arrangement

No.	Signal name	
1	A. IN Analog input	
2	0V	
3	0V	
4	+24V (+12V)	
5	RESET Reset input	
6	SW Switch input	
7	L+	Power 85~264 V AC 11~48 V DC
8	N-	
9	AL2-O	
10	A-	Analog signal output (Option)
11	A+	
12	T/R (A)(-)	Communication RS-485 (Option)
13	T/R (B)(+)	
14	0V	Pulse output
15	P.OUT	
16	AL1-C	
17	AL1-O	
18	AL2-C	

■ Connection

■ Connection of power source

For AC power

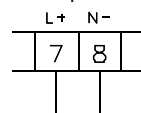

AC85~264V

For DC power

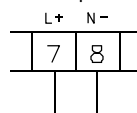

DC11~48V

■ Connection of analog signal input

(Use shielded cable)

● Connect with 2 wire type generator

Generator need power source      Generator does not need power source

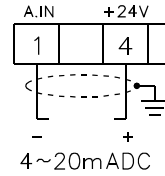

4~20mADC

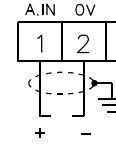

● Connect with 3 wire type generator

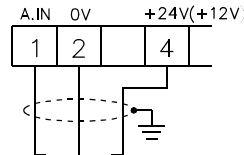

3 wire signal generator

■ Connection of reset signal input

(Use shielded cable)

For no-voltage contact signal

For open collector signal

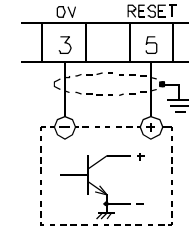
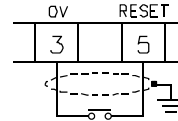

■ Connection of switch signal input

(Use shielded cable)

For no-voltage contact signal

For open collector signal

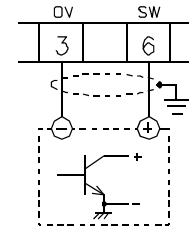
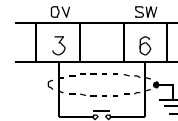

■ Connection of analog signal output (Option)

(Use shielded cable)

Analog output

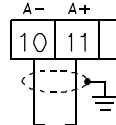

Analog output

■ Pulse output

For 12V no-contact signal  
Setting switch SSW3: ON

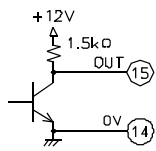

For open collector signal  
Setting switch SSW3: OFF

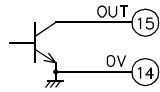

■ Comparative output

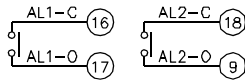

■ Connection of communication (Option)

(Use shielded cable)

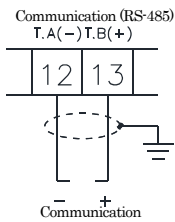

■ Connection with our large indicator by communication (Option)

(Use shielded cable)

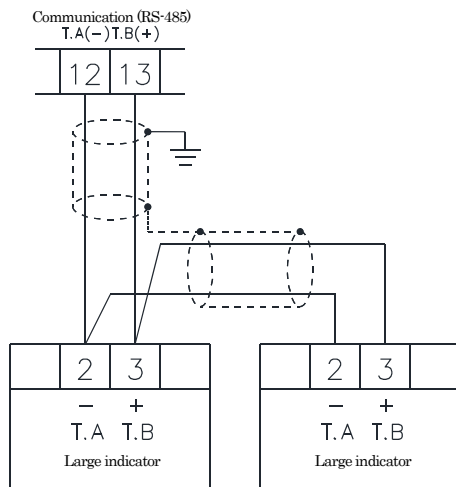

■ Model

MC82 - [ ] - [ ] [ ] [ ] - P [ ] - [ ] [ ] - [ ] [ ]

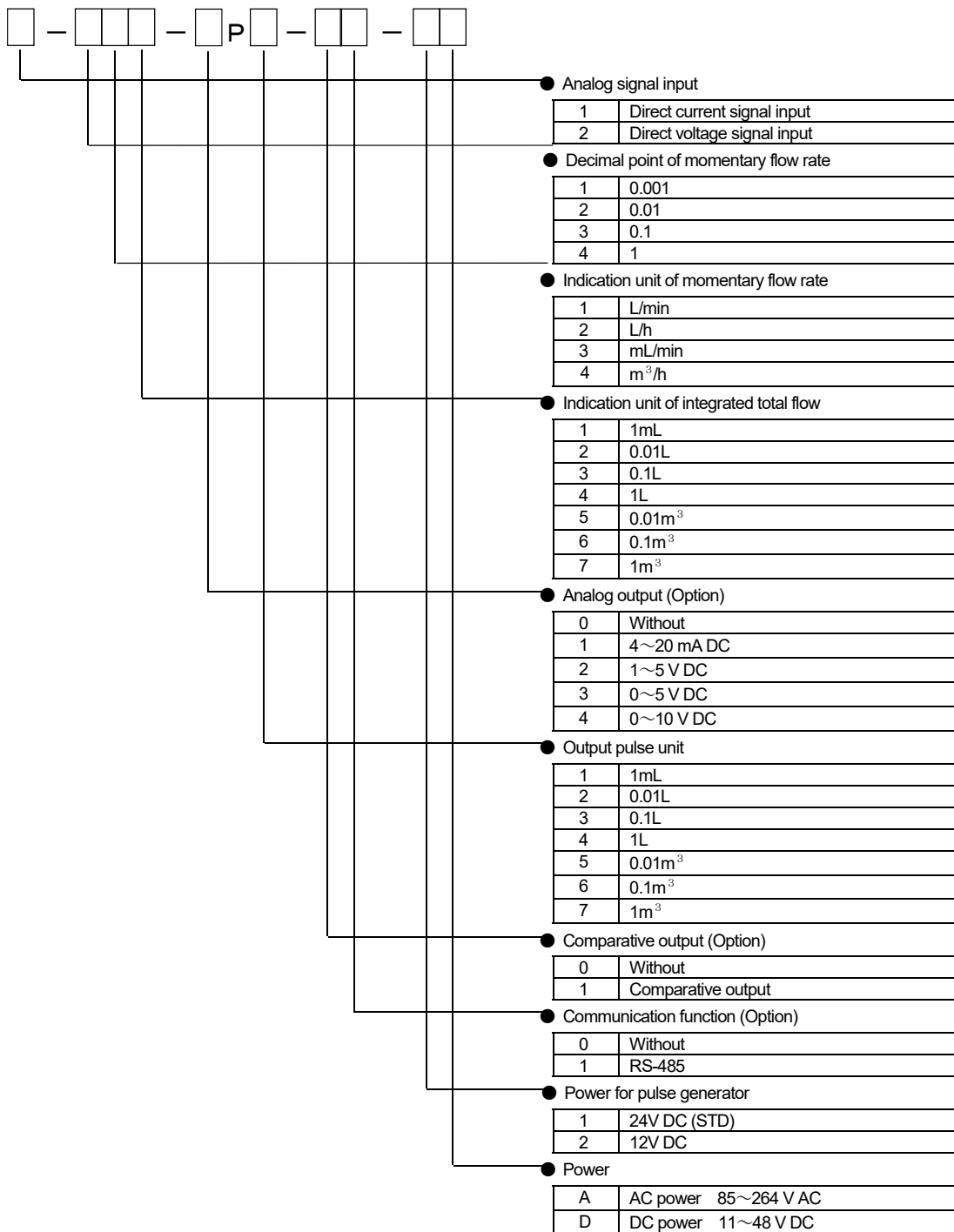

● Analog signal input

1	Direct current signal input
2	Direct voltage signal input

● Decimal point of momentary flow rate

1	0.001
2	0.01
3	0.1
4	1

● Indication unit of momentary flow rate

1	L/min
2	L/h
3	mL/min
4	m <sup>3</sup> /h

● Indication unit of integrated total flow

1	1mL
2	0.01L
3	0.1L
4	1L
5	0.01m <sup>3</sup>
6	0.1m <sup>3</sup>
7	1m <sup>3</sup>

● Analog output (Option)

0	Without
1	4~20 mA DC
2	1~5 V DC
3	0~5 V DC
4	0~10 V DC

● Output pulse unit

1	1mL
2	0.01L
3	0.1L
4	1L
5	0.01m <sup>3</sup>
6	0.1m <sup>3</sup>
7	1m <sup>3</sup>

● Comparative output (Option)

0	Without
1	Comparative output

● Communication function (Option)

0	Without
1	RS-485

● Power for pulse generator

1	24V DC (STD)
2	12V DC

● Power

A	AC power	85~264 V AC
D	DC power	11~48 V DC

▼ The contents and description are subject to change without notice.

**NITTOSEIKO CO.,LTD.**



Control System Division Global Sales Section [Website] [Inquiry Form]  
 Website: <https://global.nittoseiko.com/>