

BATCH COUNTER PH4

SPECIFICATIONS

SSF70351 25.07

General

Receives pulse signal from flowmeter, and multiplies it by flowmeter factor to indicate integrated flow rate.

Also makes comparison with set value, and outputs control signals to valve, pump, etc. to perform batch of a fluid accurately.

Features

- Keeps 10 different kinds of batch set value in memory. Indication or a change of batch set value can be made easily with the set switch on the front face.
- Prevents shocks by water hammer to the piping and improves metering accuracy, PH4 has 2-step open/close control of the valve.
- Can set an estimated quantity of overshoot, to enable accurate batch.
- Missing pulse are detected, and measuring can be stopped automatically after the set time.
- Can set an excess quantity of overshoot, and can thus detect any excessive measure.
- Enables manual actions for air bleeding, cleaning of piping, etc.
- It can perform comparison with total quantity, and make a stop of output or batching. The total counter can also be changed into a counter of the number of times of batch-end.
- Enables input of set value by external ten keys. (Option).
- Use the RS-485 communication system to set batch quantities and control START/STOP/RESET. Total count values (or batch count value and batch quantity) can be specialized large-scale displays without programming. (Option)
- Protection class of front panel are IP65.
- Terminal covers are installed as standard equipment.
- The product lineup includes a model with pressure-resistant explosion-proof enclosure, for hazardous areas. Contact NITTO SEIKO for more information. (Model: EX3E-PH4)

Specifications

Pulse input

Voltage no-contact input (SIG1)	
Frequency	5kHz or less (ON / OFF ratio 1 : 1)
	Select from voltage input/open collector input. (Select with rear DIP switch)
Voltage input	
Signal level	H: 5 to 30 V L: 0 to 2 V
Input resistance	Approx. 15 kΩ
Open collector input	
Voltage / Current	Approx. 10 V / 3.6 mA
On level	2 V or less
No-voltage contact input (SIG2)	
Frequency	30 Hz or less (ON / OFF ratio 1 : 1)
Input resistance	Approx. 4.7 kΩ

Counter

Decimal 6-digit counter, red 7-segment LED, 7.5 (W) x 10 (H)	
Batch (COUNT):	6-digit, zero suppress
Total (TOTAL):	6-digit, zero-suppress (without zero-suppress when overflow)

Scaling

Factor:	0.1000 ~ 0.9999 (Factor = 1.0000 at 0.0000)
Dividing:	1/1, 1/10, 1/100, 1/1000, 1/10000

Decimal point (Select in data settings)

Select from among None / First / Second.

Batch type (Select in data settings)

- Type 1: Automatic reset, overshoot quantity not counted
- Type 2: Manual reset, overshoot quantity not counted
- Type 3: Manual reset, overshoot quantity counted
(The overshoot quantity can be reduced by setting the expected quantity in advance.)
- Type 4: Manual reset, overshoot quantity counted
(The overshoot quantity can be reduced by automatically changing the settings for the expected overshoot quantity for the next measurement, based on the overshoot quantity and expected overshoot quantity from the previous measurement.)



Set values

Batch quantity:	Set at 10 points, in 6 digits (MAIN, MEMO1~9)
Predicted quantity:	Set at 1 point, in 4 digits (SUB) (The deviation quantity from the expected quantity is set as the SUB setting value and used as the notification quantity.)
Initial quantity:	Set at 1 point, in 4 digits (Set in advance)
Estimated overshoot quantity:	Set at 1 point, in 4 digits (Set in advance)
Excess overshoot quantity:	Set at 1 point, in 4 digits (Set in advance)
Total quantity:	Set at 1 point, in 6 digits (TOTAL)
Setting location:	Local & Remote & Communication / Remote / Remote & Communication / Communication (Select in data settings) Local: Front surface switches input. Remote: External numerical keypad (Option) Communication: RS-485 communication input. (Option)
Setting display:	Decimal 6-digit display, 7-segment LED in green color, 5.5 (W) x 8 (H)
Setting value number display:	Indication in 1 digit (0 ~ 9, A, b, t), 7-segment LED in green color, 5.5 (W) x 8 (H)

Operation

Operation location:	Local & Remote & Communication / Remote / Remote & Communication / Communication (Select in data settings)
Local:	Front surface switches input. (START, STOP, RESET)
Remote:	Terminals input (START, STOP, RESET)
Input signal	No-voltage contact or open-collector
Signal width:	5 ms or more
Voltage / current:	Approx. 12V / approx. 4 mA
Signal level:	2V or less
Operation	START,RESET : Operation when ON STOP : Operation when ON (contact a) /Operation when OFF (contact b) (Select in data settings.)
Communication:	RS-485 communication input (Option)

Control output

In-measurement signal (MAIN), Notification signal (SUB), End-of-batch signal (END), and Status signal (STUS)	
Output points:	In-measurement signal: 2 points, Others: 1 point each
Signal type:	No-voltage contact output
Contact capacity	AC250V 5A, DC30V 5A (Resistance load)

Operation display

In-measurement display (MAIN), notification display (SUB),
End-of-batch display (END), and status signal (STUS) :
All are red LEDs of $\phi 3$

Status detection

Power outage memory detection
(notification of power OFF during operation)
Detection display : Status display flashes (STUS),
[P.StoP] displayed

Detection output : Status output ON (STUS)

Missing pulse detection
(notification of no pulse input during measurement)

Missing pulse time : Approx. 1 to 30 seconds
Detection display : Status display flashes (STUS)
Detection output : Status output ON (STUS)

Automatic stop

(measurement stops after detection of missing pulse
during measurement)

Set time : Approx. 1 to 180 seconds after detection of
missing pulse

Operation display : Status display flashes (STUS),
[A.StoP] displayed

Operation output : Status output ON (STUS)

Excessive overshoot quantity detection

Detection display : Status display flashes (STUS)
Detection output : Status output ON (STUS)

Pulse output

Signal Distributed output / Scaling output
(Select in data settings.)

Signal type 12V non-contact / Open collector
(Select with rear DIP switch)
12V non-contact signal
Signal level H: Approx. 12 V (no load),
L: 1 V or less (no load)
Output resistance Approx. 1.1 k Ω
(short-circuit protection resistance: 100 Ω)
Signal logic Positive logic / Negative logic
(Select with rear DIP switch)
Open collector signal
Voltage / Current 30 V, 30 mA
On level 0.5V or less
Signal logic Positive logic / Negative logic
(Select with rear DIP switch)

Total reset

Local Front surface switches input
[RESET] & [TOTAL]

Remote Terminals input (T.RST)
Input signals No-voltage contact ,
open collector
Signal width 5 ms or more
Voltage / Current Approx. 12 V/4 mA
Signal level 2 V or less

Communication RS-485 communication input (Option)

Total detection

Total detection
Detection conditions [total counter] \geq [total quantity]
Detection display Status display ON (STUS)
Detection output Status output ON (STUS)

Total stop operation

Operation Stop measurement during total detection
Operation display Status display ON (STUS),
[t.StoP] displayed
Operation output Status output ON (STUS)

Communication (Option)

Communication system RS-485 communication system
Transmission code ASCII code
Transmission protocol PL method / HE method
(Select in data settings.)

	PL method	HE method
ID No.	01 to 99	00 to 99
Transmission rate (bps)	2400 / 4800 / 9600	1200 / 2400 / 4800 / 9600 / 19.2k / 38.4k
Parity	None / Odd / Even	None / Odd / Even
Delay time	2 ms / 100 ms	2 ms / 100 ms
Data bits	7 bits / 8 bits	7 bits / 8 bits
Stop bits	1 bit	1 bits / 2 bits
Error check	Without BCC	Without BCC / with BCC
Transmission control	Response	Response/ Continuous transmission

Power outage memory

Flash memory

Power supply for transmitter

DC12V \pm 10%, 100 mA

Insulation resistance

DC500V, 100 M Ω or greater
(exposed metal parts, power supply terminals, and between contact output terminals)

Withstanding voltage

AC2000V, 1 minute
(Test location is the same as insulation resistance.)

Noise resistance

Square-wave noise of 1,000 V using noise simulator (Width of 1 μ S, \pm polarity, power supply synchronized application, phase of 0 to 360)

Power supply

Alternating current power supply: AC 85 to 264 V, 50 / 60 Hz

Direct current power supply: DC 20 to 30 V, ripple rate 5% or less

Power consumption

10 VA or less (AC),
10 W or less (DC)

Ambient temperature

-10 to 50 $^{\circ}$ C
(with no condensation)

Mass

Approx. 0.5 kg

Chassis

Case: ABS
Terminal board, terminal cover: polycarbonate

Protection class

Front panel IP65

■ Dimensions • Panel cut

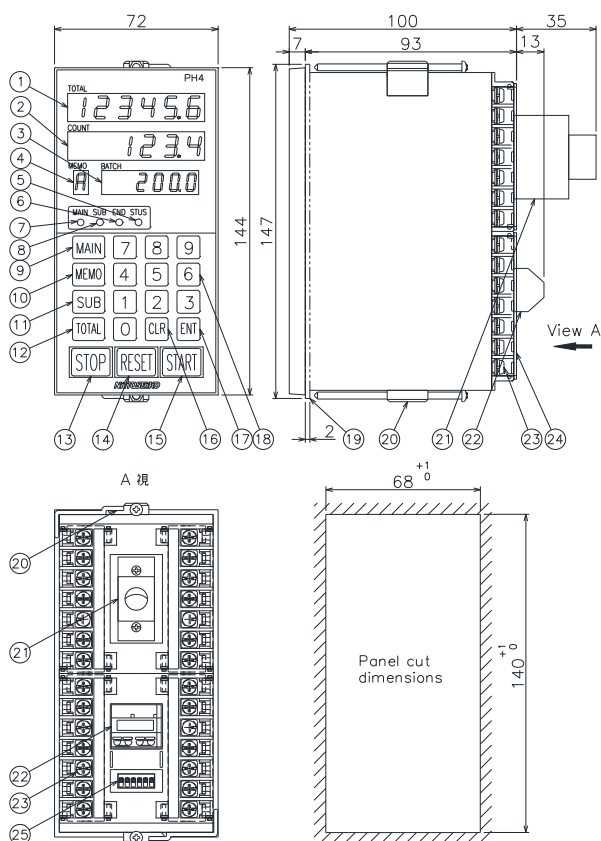

No.	Name	No.	Name
1	Total count display (TOTAL display)	14	RESET switch
2	Batch count display (COUNT display)	15	START switch
3	Batch quantity display (BATCH display)	16	CLR switch
4	Setting value number display (MEMO display)	17	ENT switch
5	Status display (STUS display)	18	Numerical switches
6	End-of-batch display (END display)	19	Waterproof packing
7	In-measurement display (MAIN display)	20	Installation bracket (2 locations)
8	Notification display (SUB display)	21	External numerical keypad connector *1
9	MAIN switch	22	Network terminal board *1
10	MEMO switch	23	Terminal board (M3.5)
11	SUB switch	24	Terminal cover
12	TOTAL switch	25	DIP switches (SW)
13	STOP switch		

*1 : Option

*2 : Setting switch(SW)

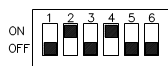

SW	Details	ON	OFF
1	Non-contact pulse input specifications	Open collector	Wet non-contact
2		Wet non-contact	Open collector
3	Pulse output specifications	Open collector	12-V non-contact
4		12-V non-contact	Open collector
5	Pulse output logic	Negative logic	Positive logic
6	Network termination resistance	Yes	No

■ Actions

● Indication of set value

- If you press the MAIN switch, "A" will be indicated on the MEMO display and the batch quantity (set value for MAIN) will be shown on the BATCH display.
- If you press 1 ~ 9 after pressing the MEMO switch, numerals will be given on the MEMO display, and the batch quantity (set value for memory) will be shown on the BATCH display.
- If you press the SUB switch, "b" will be indicated on the MEMO display and the set value for SUB will be shown on the BATCH display. (Setting of predictive quantity)
[notification quantity]=[expected quantity]-[set value for SUB]
- If you press the TOTAL switch, "t" will be indicated on the MEMO display, and the total quantity will be shown on the BATCH display.

● Changing the set value (at Panel face)

- For changing the set value indicated on the BATCH display, erase (the existing value) with the CLR switch, input a new value, and then determine it with the ENT switch.
- During a change of set value, the LED on the panel surface.
 - During a change of batch quantity:
The measuring display blinks. (MAIN)
 - During a change of set value for SUB:
The predictive display blinks. (SUB)
 - During a change of TOTAL quantity:
The status display blinks. (STUS)
- Before starting, you can press and hold one of the following numerical switches to check each of the setting values.
 - [5] : Expected overshoot quantity
 - [6] : Excessive overshoot quantity
 - [7] : Initial quantity
 - [8] : Notification quantity.
 - [9] : Expected quantity.
- To return to the initial display of batch quantity after showing the set value for SUB or total quantity, press the SUB or TOTAL switch again.
- Please reset batch display to batch quantity when START.

● Power outage memory detection

- It detects interruption of operation due to power failure while operating.
- At detection, it blinks STUS indication, and output STATUS. It indicates "P.StoP" at batch display. Please release by STOP.

● Missing pulse detection

- It detects missing pulse if signal does not input while more than setting time.
- This time can be set within a range of 0 to 30 seconds. If this time is set to 0 seconds, missing pulse detection and the automatic stop function are disabled.
- At detection, the STUS display blinks, and the status is output.
- Cancels detection if an input signal comes again during the detection.
- Can automatically stops the metering if there is no further input signal after a detection. The set time is 0 ~ 180 seconds, and a restart can be made.

● Excessive overshoot quantity detection

- In the overshoot quantity counting system, detection is made when the metering value after completion exceeded the batch quantity by the excess quantity.
- At detection, the STUS display blinks, and the status is output. The detection is cancelled with a RESET signal.

● Manual action

- If you press the MEMO switch and press the numeral 0, "Set-uP" will appear on the BATCH display. Metering signal and predictive signal are turned ON with a START signal and turned OFF with a STOP signal.

Batch Methods

Batch methods		Batch method 1	Batch method 2	Batch method 3	Batch method 4
Method	Reset	Automatic reset	Manual reset		
	Overshoot quantity	Overshoot quantity not counted		Overshoot quantity counted	
	Expected overshoot quantity	Manual setting			Automatic setting *3
Start		Press START to start measuring. The in-measurement signal comes ON, and the MAIN display comes on. Pulse signals can be counted.			
Notification signal ON		If batch count is the initial quantity, the notification signal comes ON and the SUB display comes on.			
Stop		Press STOP to interrupt measuring. The in-measurement signal and notification signal go OFF, and the MAIN and SUB displays go off. The counter is not reset. Whether or not the pulse signal is counted while the system is stopped can be selected in the data settings for counting operations when the system is stopped.	Press STOP to interrupt counting. The in-measurement signal and notification signal go OFF, and the MAIN and SUB displays go off. The counter is not reset. The pulse signal can be counted even when the system is stopped.		
Restart		Press START to restart measuring. The in-measurement signal comes ON, and the MAIN display comes on. Pulse signals can be counted.			
Notification signal ON after restart		If the initial quantity is reached, the notification signal comes ON and the SUB display comes on.			
Notification signal OFF		If batch count reaches the notification quantity (notification quantity = batch quantity - expected overshoot quantity - SUB setting value), the notification signal goes OFF and the SUB display goes off.			
Measurement end (In-measurement signal OFF)		If the batch count reaches the expected quantity (expected quantity = batch quantity - expected overshoot quantity), the in-measurement signal goes OFF and the MAIN display goes off.			
End-of-batch	If the data setting for the end-of-batch selection is the expected quantity	If the batch count reaches the expected quantity, and after the end-of-batch delay time has elapsed, the end-of-batch signal comes ON and the END display comes on while end-of-batch is output. The pulse signal can be counted until the batch quantity is reached.	If the batch count reaches the expected quantity, and after the end-of-batch delay time has elapsed, the end-of-batch signal comes ON and the END display comes on. The pulse signal can be counted until the batch quantity is reached.	If the batch count reaches the expected quantity, and after the end-of-batch delay time has elapsed, the end-of-batch signal comes ON and the END display comes on. The pulse signal can be counted until RESET is performed.	
	If the data setting for the end-of-batch selection is the batch quantity	If the batch count reaches the batch quantity, and after the end-of-batch delay time has elapsed, the end-of-batch signal comes ON and the END display comes on while end-of-batch is output. The pulse signal can not be counted.	If the batch count reaches the batch quantity, and after the end-of-batch delay time has elapsed, the end-of-batch signal comes ON and the END display comes on. The pulse signal can not be counted.	If the batch count reaches the batch quantity, and after the end-of-batch delay time has elapsed, the end-of-batch signal comes ON and the END display comes on. The pulse signal can be counted until RESET is performed.	
		If the overshoot quantity is low, and the batch count does not reach the batch quantity, the end-of-batch signal does not come ON. If the adjustment operation data setting is set to "AJSt", when START is pressed the in-measurement signal comes ON and the MAIN display comes on. (The notification signal does not come ON.) If STOP or the batch count reaches the batch quantity, the in-measurement signal goes OFF and the MAIN display goes off.			
Reset		The end-of-batch signal comes ON while end-of-batch is output (and the END display comes on at the same time), and when it goes OFF the batch counter is automatically reset. The system waits for the next measurement (start).	The end-of-batch signal goes OFF during a RESET, the END display goes off, and the batch counter is reset. The pulse signal can not be counted. The system waits for the next measurement (start). If a RESET is performed before the end-of-batch delay time has elapsed, the end-of-batch signal comes ON while end-of-batch is output without waiting for the delay time (and the END display comes on at the same time), and when it goes OFF the batch counter is automatically reset.		

*3: The settings for the next expected overshoot quantity are automatically changed based on the overshoot quantity and expected overshoot quantity from the previous measurement. For the initial measurement, the expected overshoot quantity configured in the data settings is used. Pressing the switch [5] before measuring starts will show the current expected overshoot quantity. Holding the switch [5] down and pressing [CLR] will reset the expected overshoot quantity to the value set in the data settings.

■ Time Chart

[When using a 2-stage on/off valve]

You can use the notification signal (SUB), SUB setting value, and initial quantity to perform 2-stage on/off operations of the valve, for accurate quantitative measurement, and to prevent pipe damage and static electricity. In the following examples, the expected overshoot quantity is set to 0.

- For batch methods 1 and 2

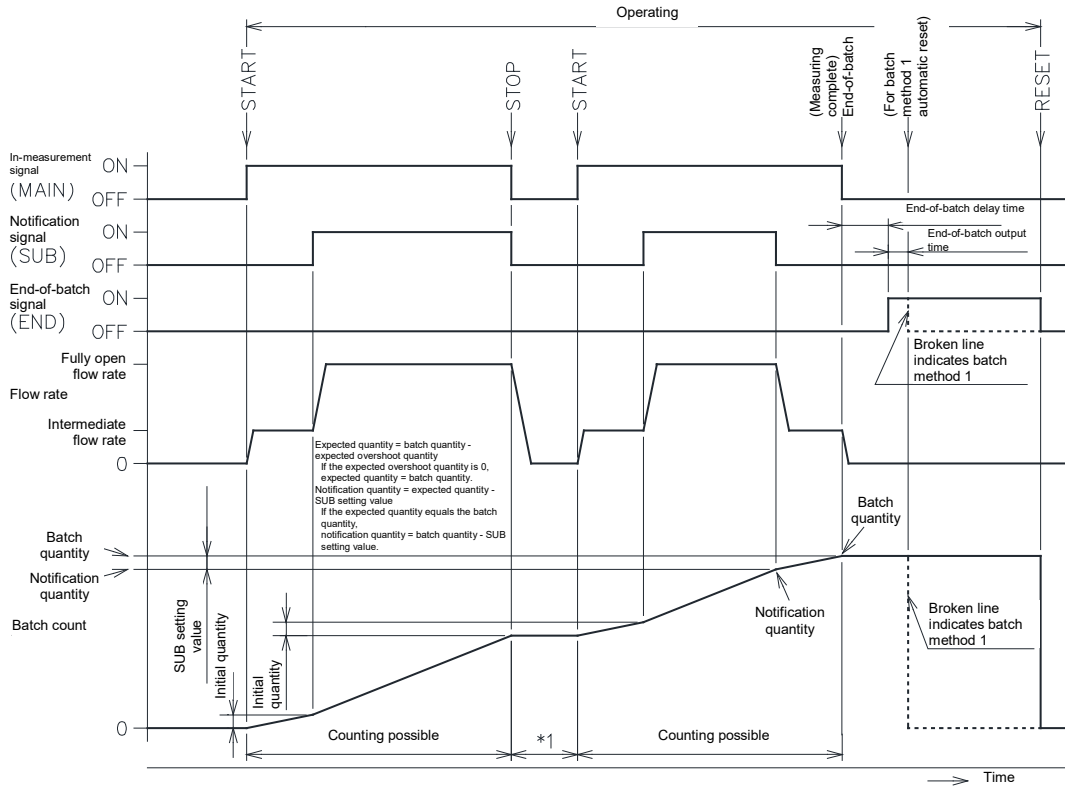

*1: Counting is possible if the data setting for counting during a stop is "noStoP".

- For batch methods 3 and 4

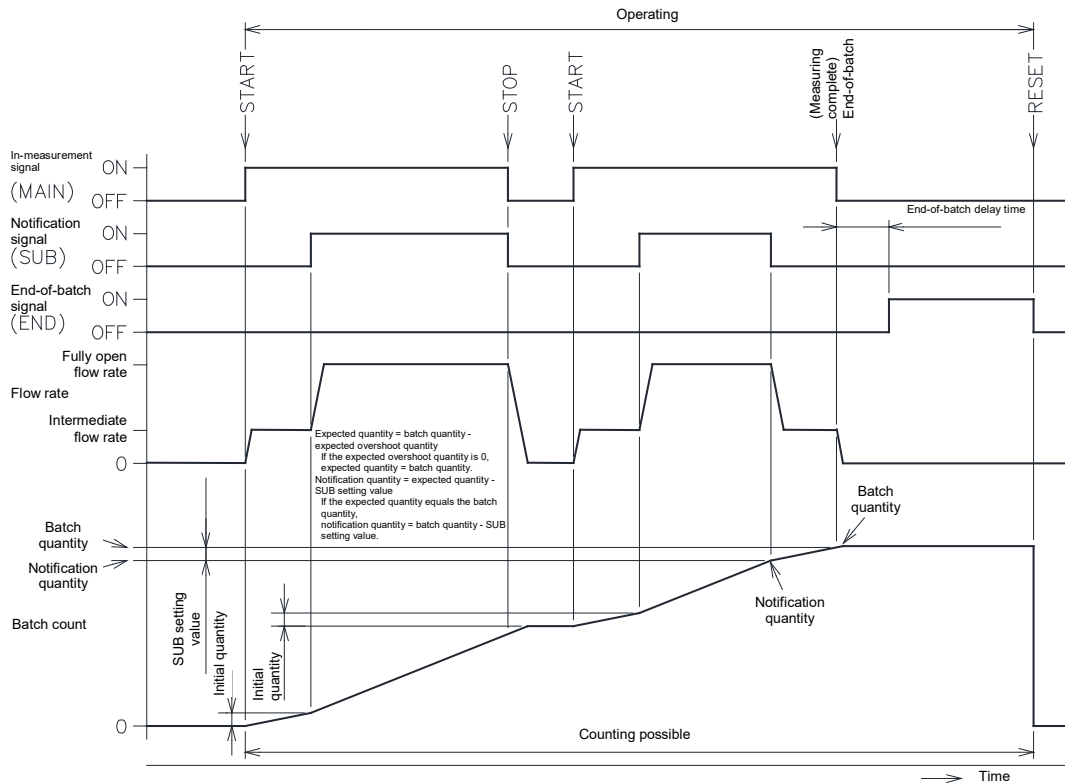

[When using a 1-stage on/off valve]

Even when using a 1-stage on/off valve, you can use the expected overshoot quantity to perform accurate quantitative measurement.

In the following examples, the setting value for the initial quantity is 0 and the SUB setting value is also 0.

- For batch methods 1 and 2

If the data setting for the end-of-batch selection is the expected quantity

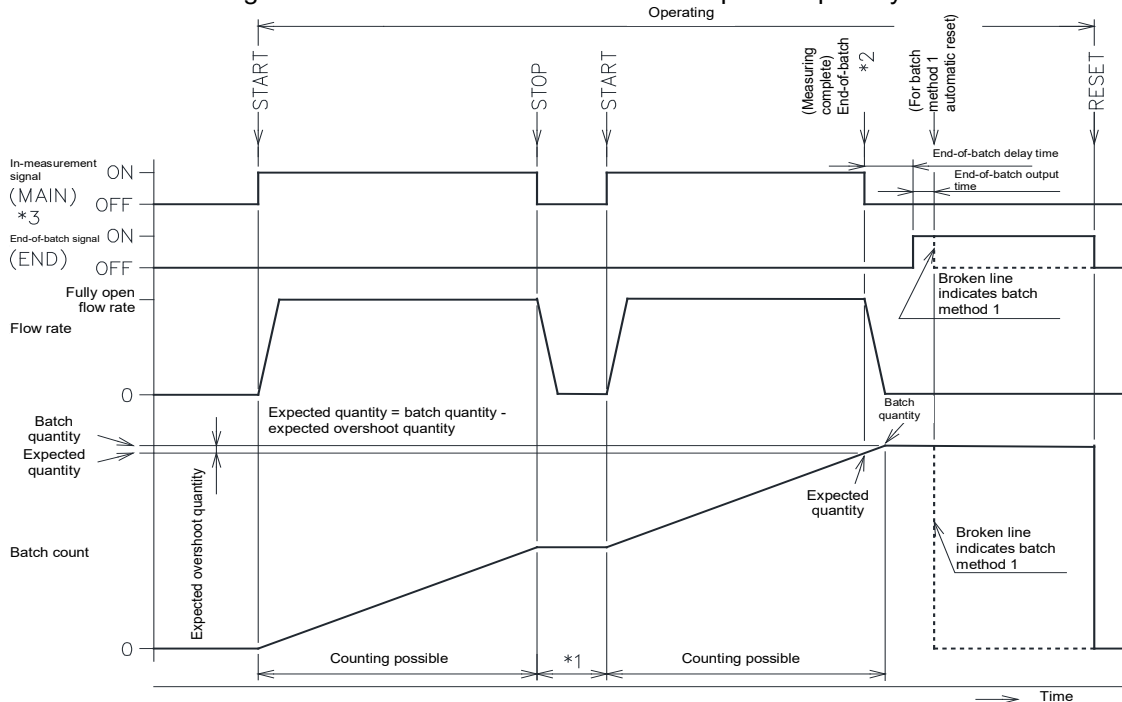

*1: Counting is possible if the setting for counting during a stop is "noStoP".

*2: If the data setting for end-of-batch selection is batch quantity, end-of-batch is determined by batch quantity and the end-of-batch signal comes ON after the end-of-batch delay time. However, if the overshoot quantity is low and the count does not reach the batch quantity, the end-of-batch signal will not come ON and an automatic reset will not occur.

*3: The notification signal (SUB) and in-measurement signal (MAIN) go ON and OFF at the same time. (If the initial quantity is 0 and the SUB setting value is also 0)

- For batch methods 3 and 4

If the data setting for the end-of-batch selection is the expected quantity

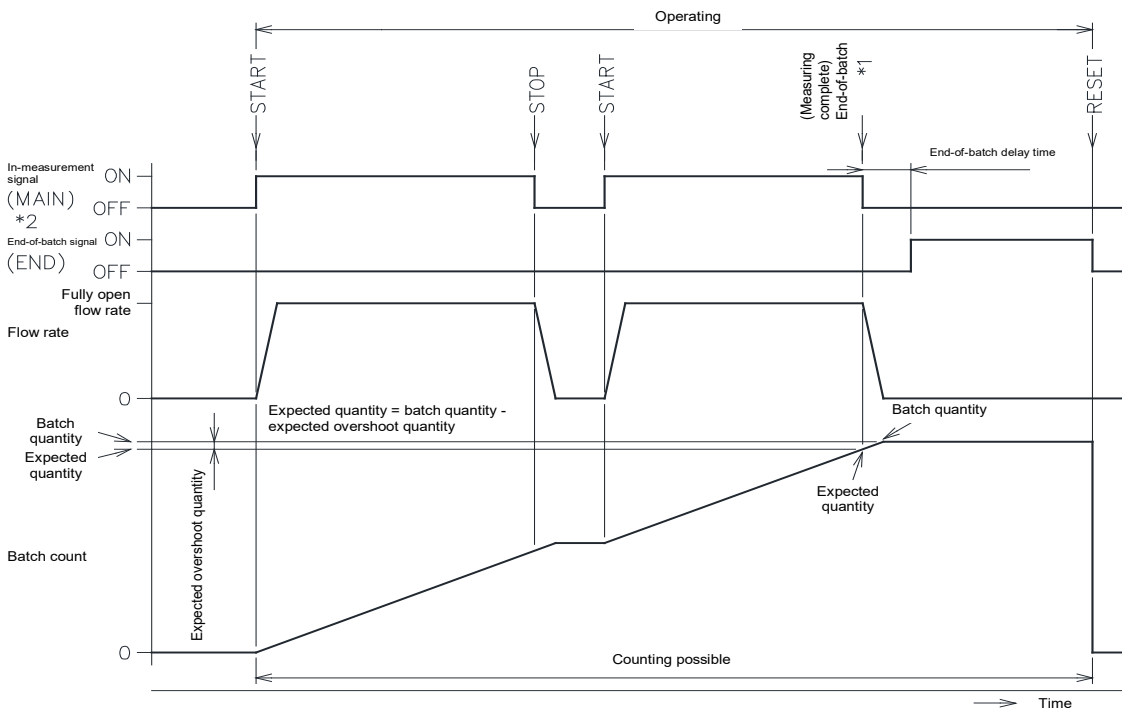

*1: If the data setting for end-of-batch selection is batch quantity, end-of-batch is determined by batch quantity and the end-of-batch signal comes ON after the end-of-batch delay time. However, if the overshoot quantity is low and the count does not reach the batch quantity, the end-of-batch signal will not come ON.

*2: The notification signal (SUB) and in-measurement signal (MAIN) go ON and OFF at the same time. (If the initial quantity is 0 and the SUB setting value is also 0)

● **Adjusting action**

- When end-of-batch selection is batch quantity, and when batch count does not reach to batch quantity because of excess quantity overshoot is less than predicted value, additional filling by manual is available.
- It turn on the in-measurement signal at START, and measures flow volume. And it turn off the in-measurement signal at STOP or when batch count reaches to batch quantity.
- It does not turn on the notification signal.

● **Pulse output**

- Distribution pulse is an output synchronizing with the input signal.
- Scaling pulse is an output synchronizing with the count value after scaling with a flowmeter factor. The pulse width can be selected from among 0.1 ms, 0.5 ms, 1 ms, 5 ms, 10 ms, 50 ms, 100 ms and 1000 ms.
- The output specifications and the output logic can be changed with a setting switch behind the PH3

● **Total counter**

- Selection can be made for either flow rate counter or counter of number of times of completion.
- It can be reset by pressing TOTAL switch while pressing RESET switch. And also, it can be reset by input the total reset signal.
- When the total value exceeded the total quantity, the STUS display lights, and the status is output. (Total detection)
- Can automatically stop the metering in case a total is detected during a metering action (Total-stop function)

● **Connection of external ten keys (Optional)**

- 16 (4x4) ten keys (prepared by the user) can be connected, to input set value by remote operation.
- The connection is made by using external ten-key connector provided on the back face of the instrument body. Keep the circuit resistance no higher than 50Ω.

● **Communication (Optional)**

(Refer to the instruction manual for the details.)

- Communication can be made by RS-485 system. The connection is made on the terminal block for communication.
- Communication method can be selected from two PL method and HE methods.
- Communication contents of PL method is as below.
 - (1) Readout of indication value and setting value.
 - (2) Selection and indication of batch quantity (setting value).
 - (3) Entry of setting value.
 - (4) Readout condition of contact signal.
 - (5) START, STOP, RESET, and TOTAL RESET
- Communication contents of HE method is as below.
 - (1) Readout of indication value (TOTAL, COUNT, and BATCH).
 - (2) Readout condition of contact signal.

■ **Terminal layout**

● **Terminal**

Status signal output STUS	28	14	Notification Signal output SUB
	27	13	
	26	12	
Total reset signal input T.RST	25	11	End-of-batch Signal output END
0V	24	10	
Stop signal input STOP	23	9	
Reset signal input RESET	22	8	In-measurement Signal output MAIN
Start signal input START	21	7	
0V	20	6	
Pulse output P.OUT	19	5	In-measurement Signal output MAIN
Contact pulse input SIG2	18	4	
Non-Contact pulse input SIG1	17	3	
+12V	16	2	L (+)
0V	15	1	N (-)

■ **Connection**

● **Connection of power source**

AC power source

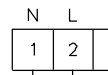

AC100~240V

DC power source(Optional)

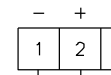

DC20~30V

● **Connection of pulse input signal**

(Use shielded cable)

Voltage no-contact input (SW1:OFF, SW2:ON)

Voltage no-contact signal

Transmission flowmeter

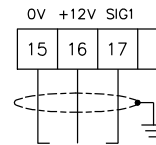

Flowmeter

Voltage no-contact signal

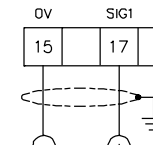

Open collector input

(SW1:ON, SW2:OFF)

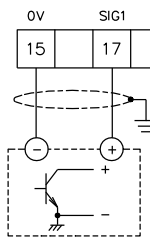

Contact input

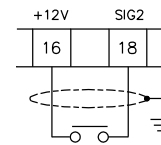

● Connection a remote control input signal
(Remote operation) (Use shielded cable)

For no-voltage contact signal For open collector signal

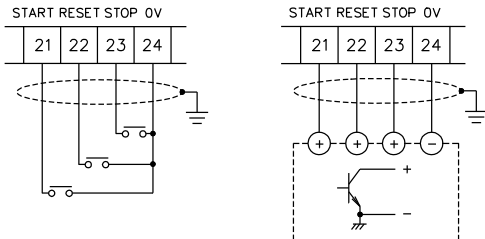

● Connecting a total reset input signal (Remote operation)
(Use shielded cable)

For no-voltage contact signal For open collector signal

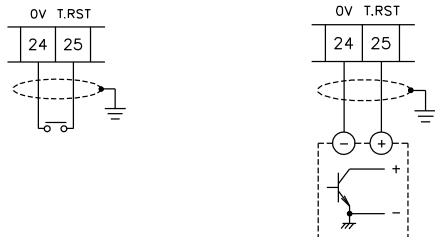

● Connecting an external numeral keypad(Optional)
(Remote setting)

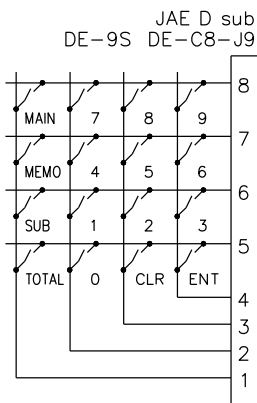

● Connecting a communication(RS-485)(Optional)

Use twisted pair shielded cables for communications.

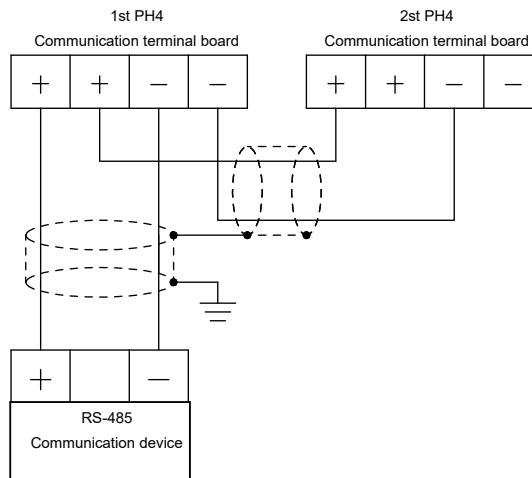

● Pulse output (Use shielded cable)

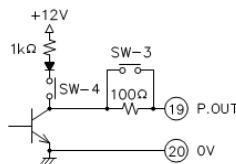

Signal type	SW-3	SW-4
12V non-contact	OFF	ON
Open collector	ON	OFF

■ Type

Type	Specification code	Remark
PH4		Batch counter
Setting Indication	-2062A	2-stage setting 6-digit electronic display
Power source	A	Power : 85~264VAC
	D	Power : 20~30VDC ※
Setting	0	Standard setting
	1	Specified setting ※
Optional	/KY	For external numeral keypad ※
	/RS	For RS-485 ※
	/KR	/KY and /RS ※

※:Optional

■ Standard setting

The instrument is delivered with the following setting in the normal case:

- Batch action: Batch system 1
Initial quantity: None
Pulse non-arrival time: 15sec, without automatic stop.
- Pulse output: Distribution output (12V no-contact output)
- Scaling: Set in the case where the connected flowmeter is known.

*** Matters to be specified at the time of ordering ***

1. Type, specification code.
2. Input pulse unit, output pulse unit.

▼The contents given here are subject to change without notice.

NITTOSEIKO CO.,LTD.



Control System Division Global Sales Section [Website] [Inquiry Form]
Website: <https://global.nittoseiko.com/>