

TURBINE FLOW METER

SPECIFICATIONS

SST10151 25.07

■ Feature

- Excellent durability and stability with special materials adopted for main bearings.
- Also usable for liquids containing a lot of foreign matters and liquids with large fluctuations in pressure or flow rate.
- Can be mounted in any position on the piping, such as in vertical, horizontal and inclined positions.
- Water-proof indication enables to set on outdoor or pit application.
- Remote indication, remote recording and remote control is available in combination with pulse generator.



■ Specification

Measured liquid	Tap water, Industrial water, Underground water, Cold and hot water, Drain water, Sea water
Nominal size	50~350 mm
Liquid temperature	0~60°C, 60~150°C (High temperature specification)
Liquid pressure	1.0 MPa or less (2.0MPa or less by Flange standard)
Accuracy	Within ±2.0%

■ Flow range (m³/h)

Nominal size symbol	Plastic wheel (80°C or less)		Metal wheel(Special type) (80~150°C or less)
	Standard	Special	
050	4 ~ 25	6 ~ 30	6 ~ 30
075	8 ~ 50	12 ~ 80	15 ~ 80
100	10 ~ 80	30 ~ 150	30 ~ 150
125	15 ~ 120	40 ~ 240	45 ~ 220
150	20 ~ 150	60 ~ 300	60 ~ 300
200	30 ~ 250	80 ~ 500	80 ~ 500
250	40 ~ 350	100 ~ 600	100 ~ 600
300	60 ~ 450	150 ~ 800	150 ~ 800
350	100 ~ 650	—	200 ~ 1000

Note: Please select the nominal size of which 40~60% of max flow rate is same as usual flow rate.

■ Pressure loss chart

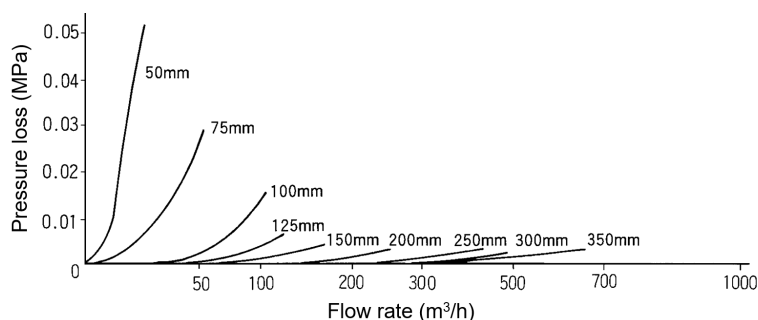

■ Material

Symbol	Body	Internal structure	Wheel	Max pressure
FB	FC200	CAC406	Plastic	1.0 MPa
DB	FCD450	CAC406	(80°C or less)	2.0 MPa
F7	FC200	SCS13	SUS304L	1.0 MPa
D7	FCD450	SCS13	(80~150°C or less)	2.0 MPa
S7	SCS13	SCS13	For S2 SUS316L	1.0 MPa or
S2	SCS14	SCS14	(80~150°C or less)	2.0 MPa

FC200 Cast Iron CAC406 Cast bronze SCS13, 14 Stainless Steel Casting
 FCD450 Ductile Cast Iron SUS304L, 316L Stainless

■ Indication unit

● Direct totalizing type

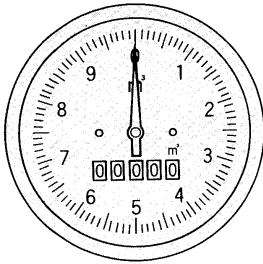

※ In case of KH type, the indication unit is 1/10 of this list.

Nominal Size (mm)	Flow Meter Model	Scale Plate		Total Counter		
		Minimum Unit (L)	One Turn (m ³)	Minimum Unit (m ³)	Digits	Max Total Indication (m ³)
50	KA 50	10	1	1	5	99,999
75	KA 75	10	1	1	5	99,999
100	KA 100	10	1	1	5	99,999
125	KA 125	10	1	1	5	99,999
150	KA 150	100	10	10	5	999,990
200	KA 200	100	10	10	5	999,990
250	KA 250	100	10	10	5	999,990
300	KA 300	100	10	10	5	999,990
350	KA 350	100	10	10	5	999,990

● Set back counter and pointer with totalizer

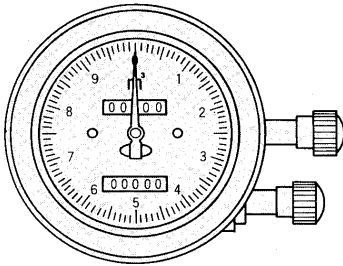

Two counter are provided, one can be set back and another one indicates totalized figure consecutively.

Nominal Size (mm)	Flow Meter Model	Scale Plate		Total Counter					
		Minimum Unit (m ³)	One Turn (m ³)	Resetable total counter			Continuous total counter		
				Digits	Minimum Unit (m ³)	Max Total Indication	Digits (m ³)	Minimum Unit	Max Total Indication (m ³)
50	KZ 50 - Z06	10L	1	5	1	99,999	1	5	99,999
75	KZ 75 - Z06	10	1	5	1	99,999	1	5	99,999
100	KZ 100 - Z06	10	1	5	1	99,999	1	5	99,999
125	KZ 125 - Z06	10	1	5	1	99,999	1	5	99,999
150	KZ 150 - Z06	100	10	5	10	999,990	10	5	999,990
200	KZ 200 - Z06	100	10	5	10	999,990	10	5	999,990
250	KZ 250 - Z06	100	10	5	10	999,990	10	5	999,990
300	KZ 300 - Z06	100	10	5	10	999,990	10	5	999,990
350	KZ 350 - Z06	100	10	5	10	999,990	10	5	999,990

■ Dimension

● Liquid temperature : 0~60°C

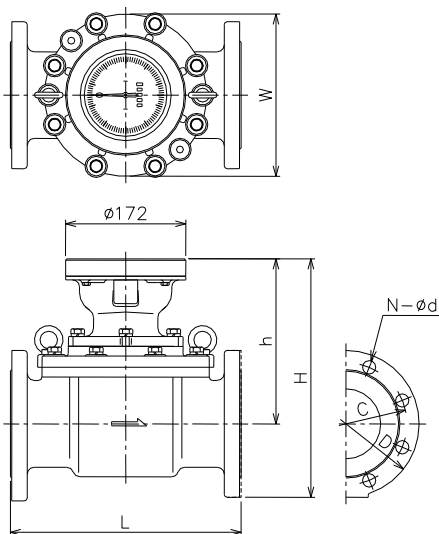

Nominal Size (mm)	External dimension				Frang dimension				Weight kg
	L	H	h	W	D	C	N	d	
50	250	291	213	192	155	120	4	19	26
75	300	316	223	226	185	150	8	19	33
100	330	341	236	236	210	175	8	19	43
125	350	385	260	264	250	210	8	23	59
150	400	412	272	310	280	240	8	23	76
200	480	465	300	392	330	290	12	23	138
250	560	520	320	462	400	355	12	25	194
300	660	568	345	552	445	400	16	25	280
350	700	590	350	552	490	445	16	25	303

The size of above is for JIS 10K flange.

● Liquid temperature : 60~150°C

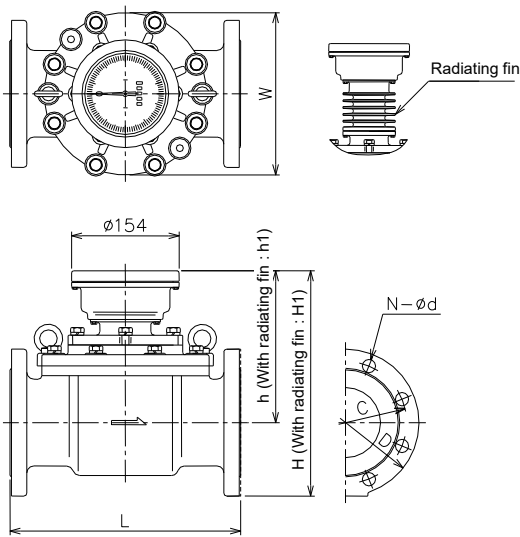

Nominal Size (mm)	External dimension				Frange dimension				Weight kg
	L	H	h	W	D	C	N	d	
50	250	269	191	192	155	120	4	19	26
75	300	294	201	226	185	150	8	19	33
100	330	319	214	236	210	175	8	19	43
125	350	363	238	264	250	210	8	23	59
150	400	390	250	310	280	240	8	23	76
200	480	443	278	392	330	290	12	23	138
250	560	498	298	462	400	335	12	25	194
300	660	546	323	552	445	400	16	25	280
350	700	568	323	552	490	445	16	25	303

The size of above is for JIS 10K flange.

In case of over 130°C of liquid temperature, needs the radiating fin.

H1=H+100

h1=h+100

■ Unit pulse generator

Reed switch pulse generator (Symbol : R)

Type	Output signal	Max. voltage	Max. current	Switch capacity	Contact resistance	Max. generated pulse
DRR-5	No-voltage contact pulse	200VAC·DC	1A	25W	0.06Ω	5P/sec
MR506	No-voltage contact pulse	50VDC	250mA	15W	0.1Ω	5P/sec

High frequency pulse generator (Symbol : M)

Output signal: Voltage no-contact pulse

Approximate rectangular wave

H: 17V or more (10 kΩ load) (+V = 24VDC)
 H: 8V or more (10 kΩ load) (+V = 12VDC)
 L: 0.5V or less (10 kΩ load)

Output resistance: Approx. 2.4kΩ

Output circuit

Max. generated pulse: 110P/sec
 Power source: 6~26.4VDC
 Power consumption: 23 mA or less (+V = 24VDC)
 17 mA or less (+V = 12VDC)

Remote measurement system

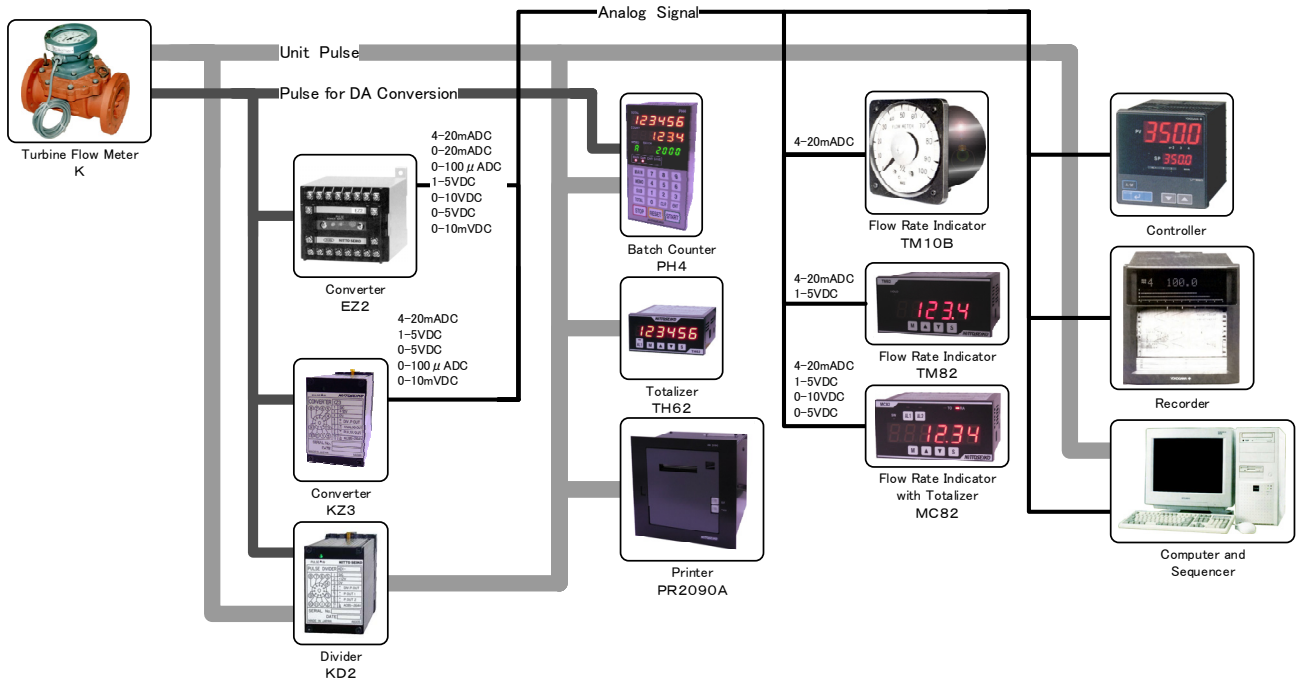

※The detailed input/output conditions vary depending on the specifications of the respective converter and receivers. Check with the specification sheet of the respective instruments.

■ Kind and feature of pulse generator

Nominal Size (mm)	Flow Meter Symbol	Flow Rate at 1 Pulse (L/P)	Max Flow Rate (m ³ /h)	Nominal Size (mm)	Flow Meter Symbol	Flow Rate at 1 Pulse (L/P)	Max Flow Rate (m ³ /h)
50	KC 50-	M4	1	200	KC200-	M5	10
		R5	10			R6	100
		R6	100			R7	1000
		R7	1000			R8	10000
75	KC 75-	M4	1	250	KC250-	M5	10
		R5	10			R6	100
		R6	100			R7	1000
		R7	1000			R8	10000
100	KC100-	M4	1	300	KC300-	M5	10
		R5	10			R6	100
		R6	100			R7	1000
		R7	1000			R8	10000
125	KC125-	M4	1	350	KC350-	M5	10
		R5	10			R6	100
		R6	100			R7	1000
		R7	1000			R8	10000
150	KC150	M5	10	150	KC150	M5	10
		R6	100			R6	100
		R7	1000			R7	1000
		R8	10000			R8	10000

Pulser type R: Reed switch Pulse Generator
M: High Frequency Pulse Generator

■ Pulse generator for DA conversion

Same specification as high frequency pulse generator (type M) of unit pulse generator.

■ Caution of piping

Pumps, valves, bends, tapered pipe, etc should not be provide immediately before or after the meter. These items should be fitted on the outside of straight portions as following illustration.

D: Nominal size

Inlet side ···· More than 5D

Outlet side ···· More than 3D

- To fit valves

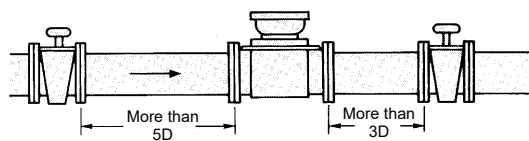

Do not adjust the flow rate with this valve which is fitted on the inlet side. The valve to adjust flow rate, should be fitted on the outlet side.

- To fit elbows

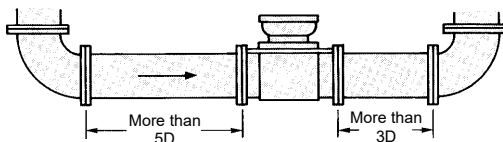

- To fit reducers

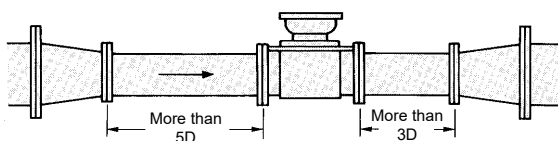

Model code

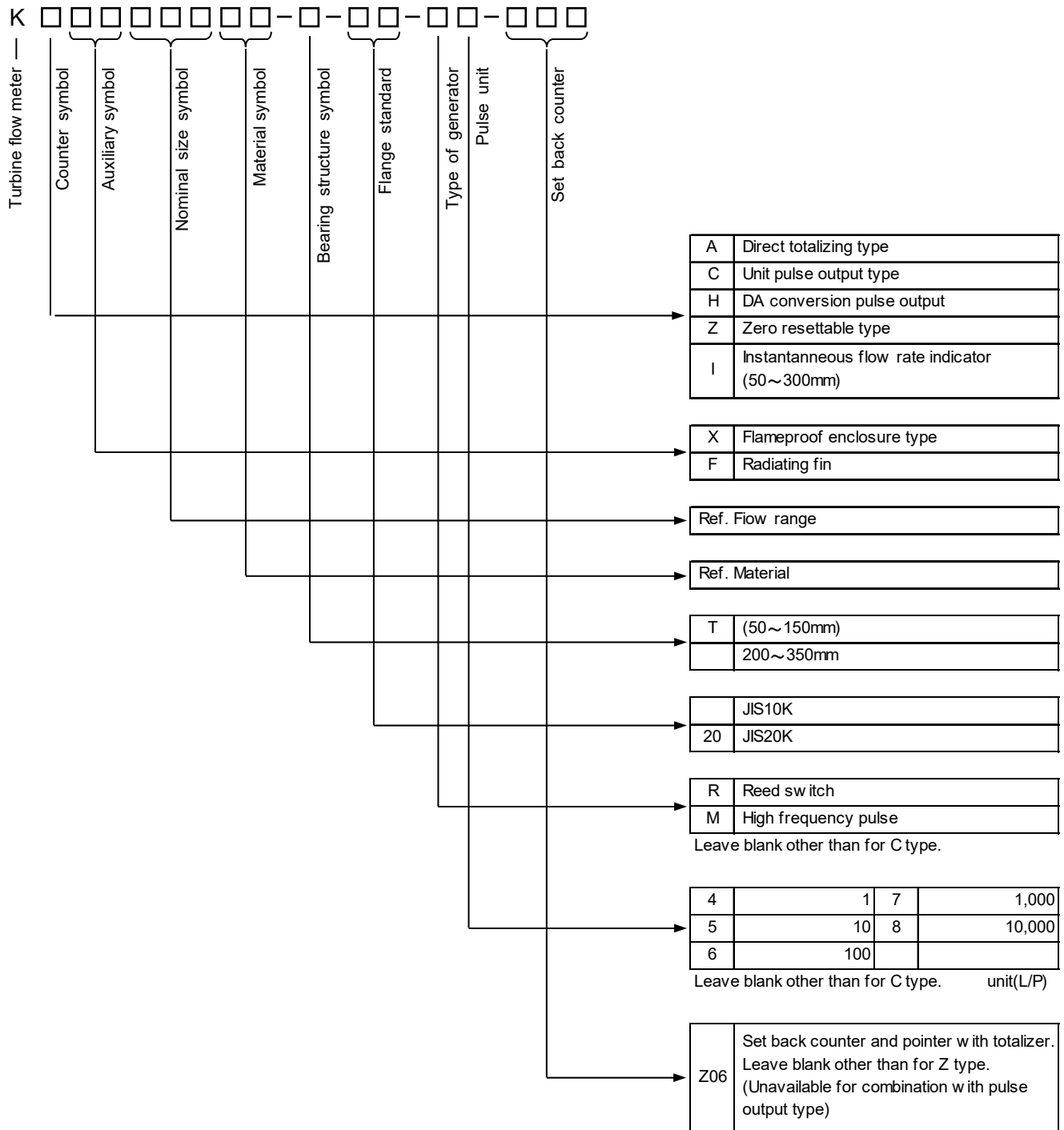

▼The contents given here are subject to change without notice.

NITTOSEIKO CO.,LTD.



Control System Division Global Sales Section . [Website] [Inquiry Form]
 Website: <https://global.nittoseiko.com/>