



# ROTARY FLOW METER

## SPECIFICATIONS

SSV10152 17.09

### 1. Outline

This is a rotary-piston flow meter of simple construction, using ceramics as standard material for the wetted bearing. For the rotor, it adopts a special plastic with excellent chemical resistance, abrasion resistance, heat resistance and impact resistance. In addition, it is a flow meter for liquid service easy to use and highly durable, using a large register for the counter unit.

### 2. Features

- Sharply improved durability, with adoption of ceramics as standard material for the wetted bearing.
- Adoption, for the rotor, of a special plastic with excellent chemical resistance, abrasion resistance, heat resistance and impact resistance.
- Easy measuring of high-viscosity liquid, with smaller pressure loss compared with other positive displacement flow meters.
- Less subject to influences of temperature and viscosity, enabling high-accuracy and stable measurement at all times.
- Large register easy to read.
- Easy expansion with variety of pulse generators available for loading



### 3. Specifications

#### Specifications of measuring unit

Nominal size symbol	025		040		050		080		100
Volume symbol	B0	A0	B0	A0	B0	A0	B0	A0	A0
Measured fluid	Chemical solutions, food liquids, petroleum, water, etc.								
Nominal size	25A		40A		50A		80A		100A
Liquid viscosity	0.5~500 mPa·s (Special 0.2 ~30,000 mPa·s)								
Liquid temperature	0~200°C (special -20~200°C for Material symbol S2)								
Liquid pressure	2.0 MPa or under (By flange standards)								
Measuring accuracy	Within ±0.5% or within ±0.2%(Counter symbol A0 only) Momentary flow rate Within ±2.0%FS								
Standard connection	Flange		JIS5K,10K, 16K,20K, ANSI class 150, 300 (For the details, see paragraph of "Process connection and face-to-face dimensions")						
Material	Material symbol	FB	Main body : FC200, Measuring chamber : CAC406, Rotor : PPS, GC, AC						
		FF	Main body : FC200, Measuring chamber : FC200, Rotor : PPS, GC, AC						
		F2	Main body : FC200, Measuring chamber : SCS14A, Rotor : PPS, GC, AC						
		DB	Main body : FCD450, Measuring chamber : CAC406, Rotor : PPS, GC, AC						
		DD	Main body : FCD450, Measuring chamber : FCD450, Rotor : PPS, GC, AC						
		D2	Main body : FCD450, Measuring chamber : SCS14A, Rotor : PPS, GC, AC						
		S2	Main body : SCS14A, Measuring chamber : SCS14A, Rotor : PPS, GC, AC						
		FC200: Cast iron; FCD450: Ductile cast iron; CAC406: Cast bronze; SCS14A: Stainless steel casting PPS: Special plastic; GC: Carbon; AC: Corrosion-resistant aluminum							
Material & permissible pressure	Nominal pressure	Flange standard		Material symbol		Permissible Pressure (Liquid Temp.~200°C) MPa			
	5K	JIS5K		FB/FF/F2		0.5			
	10K	JIS10K, ANSI class150		DB/DD/D2/S2		1.0			
	16K	JIS16K		DB/DD/D2		1.6			
	20K	JIS20K, ANSI class300		DB/DD/D2/S2		2.5			
Jacket specifications	Thermal liquid (Hot water, Steam) pressure is 0.5MPa or less. Permissible Temp. 200°C, Permissible Pressure 1.0MPa								
Special specifications	Article approved for high-pressure gas service: Only material symbol S2 is manufacturable (up to nominal size 80A). Liquid temperature -10~75°C								

## Specifications of counter unit

Nominal size symbol		025		040		050		080		100
Volume symbol		B0	A0	B0	A0	B0	A0	B0	A0	
Types		Pointer type(A 0), Zero resettable register type(Z 8), Instantaneous flow rate indicator type(I 0)								
Indication	Pointer type (A 0)	Pointer Dial plate	Dial unit	0.1 L			1 L			
			Volume per rev.	10 L			100 L			
		Total counter	Dial unit	10 L			100 L			
			Number of digits	6 ( 999,999 x 10L )			6 ( 999,999 x 100L )			
	Zero resettable register type (Z 8)	Zero-reset counter	Dial unit	0.1 L			1 L			
			Number of digits	4 ( 9,999 L )			4 ( 9,999 x 10L )			
		Continuous total counter	Dial unit	1 L			10 L			
			Number of digits	7 ( 9,999,999 L )			7 ( 9,999,999 x 10L )			
	Instantaneous flow rate indicator type(I 0)	Pointer Dial plate	Dial unit	200 L/h	500 L/h	1,000 L/h	2,000 L/h			
			Full scale	1,000~5,000 L/h	2,400~12,000 L/h	4,800~24,000 L/h	10,000~50,000 L/h			
Total counter		Dial unit	0.02 L	0.2 L			2 L			
		Number of digits	7 ( 999,999.9 L )	7 ( 9,999,999 L )			7 ( 9,999,999 x 10L )			
Output	Pulse output	Unit pulse	Type of signal	(Note) Either one of (1) voltage no-contact signal (high frequency type, photoelectric type), or (2) reed switch contact signal.						
			Output unit	No-contact pulse output : See "No-contact pulse output" table. Contact pulse output : See "Contact pulse output" table.						
		DA conversion pulse	No-contact pulse output possible							
		(Note) No simultaneous output of unit pulse and DA conversion pulse can be made.								
	Analogue output	Direct output impossible (DA converter required outside)								
Power source	The following external power sources are required, for outputting voltage no-contact signals: (1) High frequency type pulse generator: 6~26.4VDC , 23mA(at 24V DC) ,17 mA(at 12V DC) (2) Photoelectric type pulse generator: 12VDC, 50mA									
Ambient temperature	-10~60°C									
Explosion-protection	Flameproof enclosure type Exd II BT4 : Either one of high frequency pulse generator, or reed switch pulse generator									
Radiating fin	Single-stage fin in the case where the liquid temperature exceeds 130°C, and double-stage fins in the case where the liquid temperature exceeds 180°C. Instantaneous flow indicator type: Single-stage fin in the case where the liquid temperature exceeds 100°C but not exceeds 150°C									
Material	Aluminum die casting									

## Output pulse unit table (Optional)

No-contact output pulse unit table (● Photoelectric type, ○ High frequency type, ⊙ High frequency type/ Photoelectric type)

Nominal size & volume symbol	One rev. of pointer	Pulse unit						
		1mL/P	10mL/P	100mL/P	1L/P	10L/P	100L/P	1m <sup>3</sup> /P
025B0 040A0	10L	●	⊙	○	○	--	--	--
040B0 050A0	10L	●	⊙	○	○	--	--	--
	100L	--	●	⊙	○	○	--	--
050B0 080A0	100L	--	●	⊙	○	○	--	--
	1m <sup>3</sup>	--	--	●	⊙	○	○	--
080B0 100A0	100L	--	●	⊙	○	○	--	--
	1m <sup>3</sup>	--	--	●	⊙	○	○	--

Contact output pulse unit table (○ Reed switch)

Nominal size & volume symbol	One rev. of pointer	Pulse unit						
		1mL/P	10mL/P	100mL/P	1L/P	10L/P	100L/P	1m <sup>3</sup> /P
025B0 040A0	10L	--	--	○※1	○	○	--	--
040B0 050A0	10L	--	--	○※1	○	○	--	--
	100L	--	--	--	○	○	○	--
050B0 080A0	100L	--	--	--	○※1	○	○	--
	1m <sup>3</sup>	--	--	--	--	○	○	○
080B0 100A0	100L	--	--	--	○※1	○	○	--
	1m <sup>3</sup>	--	--	--	--	○	○	○

※1 : Manufacturable in case of 5P/s or less

- High frequency pulse generator (Symbol : M)

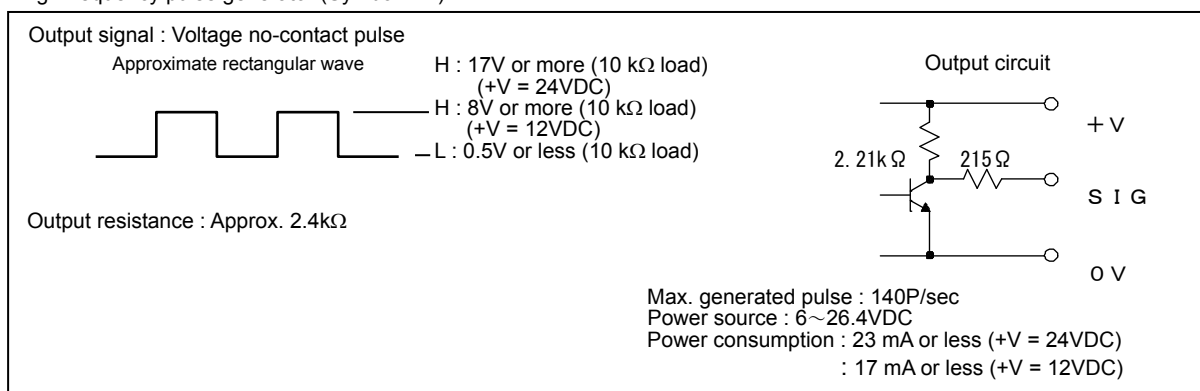

- Photoelectric pulse generator (Symbol : K)

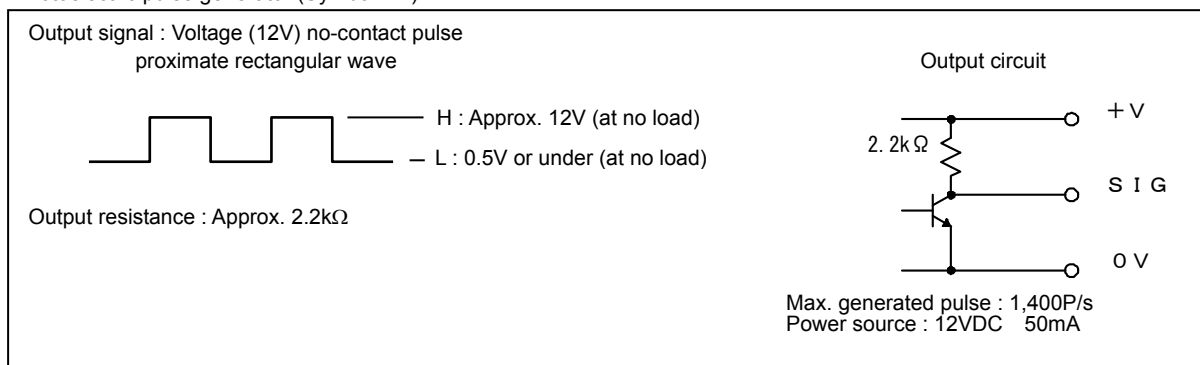

- Reed switch pulse generator (Symbol : R)

Type	Output signal	Max. voltage	Max. current	Switch capacity	Contact resistance	Max. generated pulse
DRR-5	No-voltage contact pulse	200V AC·DC	1A	25W	0.06 $\Omega$	5P/s
MR506	No-voltage contact pulse	50V DC	250mA	15W	0.1 $\Omega$	5P/s

#### 4. Range of flow rate (m<sup>3</sup>/h)

Accuracy:  $\pm 0.5\%$

Nominal size & volume symbol	Working conditions	Water (normal temperature)	Hot water (60~120°C)	0.5mPa·s~	1mPa·s~	4mPa·s~	10mPa·s~	50~500mPa·s
025B0	Continuous	0.5~2.5	0.65~2.0	0.65~3.0	0.5~3.0	0.35~3.5	0.2~3.5	0.17~3.5
	Intermittent	0.5~3.5	0.65~2.5	0.65~4.0	0.5~5.0	0.35~5.0	0.2~5.0	0.17~5.0
040A0	Continuous	1.2~6.0	1.5~4.8	1.5~7.2	1.2~7.2	0.65~8.4	0.5~8.4	0.36~8.4
	Intermittent	1.2~8.5	1.5~6.0	1.5~10.0	1.2~12.0	0.65~12.0	0.5~12.0	0.36~12.0
050B0	Continuous	2.4~12.0	3.0~9.6	3.0~15.0	2.4~15.0	1.2~17.0	1.0~17.0	0.75~17.0
	Intermittent	2.4~17.0	3.0~12.0	3.0~20.0	2.4~24.0	1.2~24.0	1.0~24.0	0.75~24.0
080B0	Continuous	5.0~25.0	6.0~20.0	6.0~30.0	5.0~30.0	2.5~35.0	2.0~35.0	1.5~35.0
	Intermittent	5.0~35.0	6.0~25.0	6.0~40.0	5.0~50.0	2.5~50.0	2.0~50.0	1.5~50.0

Accuracy:  $\pm 0.2\%$  (Counter symbol A0 only)

Nominal size & volume symbol	Working conditions	Water (normal temperature)	0.5mPa·s~	1mPa·s~	4mPa·s~	10mPa·s~	50~500mPa·s
025B0	Continuous	1.2~2.5	1.5~3.0	1.2~3.0	0.6~3.5	0.35~3.5	0.3~3.5
	Intermittent	1.2~3.5	1.5~3.5	1.2~5.0	0.6~5.0	0.35~5.0	0.3~5.0
040B0	Continuous	3.0~6.0	3.5~7.2	3.0~7.2	1.5~8.4	0.8~8.4	0.7~8.4
	Intermittent	3.0~8.5	3.5~8.5	3.0~12.0	1.5~12.0	0.8~12.0	0.7~12.0
050B0	Continuous	6.0~12.0	7.0~15.0	6.0~15.0	3.0~17.0	1.5~17.0	1.4~17.0
	Intermittent	6.0~17.0	7.0~17.0	6.0~24.0	3.0~24.0	1.5~24.0	1.4~24.0
080B0	Continuous	12.0~25.0	15.0~30.0	12.0~30.0	5.0~35.0	3.5~35.0	3.0~35.0
	Intermittent	12.0~35.0	15.0~35.0	12.0~50.0	5.0~50.0	3.5~50.0	3.0~50.0

(Note) 1. "Continuous" refers to a case where the daily operating time exceeds 8 hours, while "Intermittent" expresses a case where the daily operating time is no more than 8 hours.

2. Please select the type of which 40~60% of Max. flow rate is as same as operation flow rate.

## 5. Pressure loss

Nominal size & volume symbol : 0 2 5 B 0 ~ 1 0 0 A 0

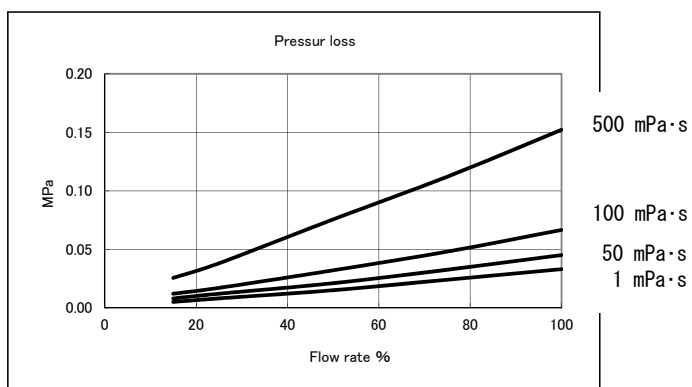

Nominal size & volume symbol	Flow rate 100%
025B0 040A0	5.0 m <sup>3</sup> /h
040B0 050A0	12.0 m <sup>3</sup> /h
050B0 080A0	24.0 m <sup>3</sup> /h
080B0 100A0	50.0 m <sup>3</sup> /h

## 6. Process connection and face-to-face dimensions (Unit : mm)

Nominal size & volume symbol	Material symbol	JIS				ANSI	
		5K	10K	16K	20K	class150	class 300
025B0	FB/FF/F2	220	220	--	--	221	--
	DB/DD/D2	220	220	220	224	221	228
	S2	220	220	--	224	221	228
040A0 040B0	FB/FF/F2	300	300	--	--	304	--
	DB/DD/D2	300	300	300	304	304	310
	S2	300	300	--	304	304	310
050A0 050B0	FB/FF/F2	370	370	--	--	378	--
	DB/DD/D2	370	370	370	374	378	384
	S2	370	370	--	374	378	384
080A0 080B0	FB/FF/F2	400	400	--	--	412	--
	DB/DD/D2	400	400	400	408	412	422
	S2	400	400	--	408	412	422
100A0	FB/FF/F2	460	460	--	--	472	--
	DB/DD/D2	460	460	460	472	472	488
	S2	460	460	--	472	472	488

### 7. Piping method

- Install a strainer on the inlet side of the flow meter without fail. To avoid outflow to the downstream side due to damage of internal component parts, install a strainer also on the outlet side of the flow meter. (Note) The standard mesh of the strainer element is 60 meshes.
- Install a bypass piping. In designing this bypass piping, take account of protection of the inner elements of the flow meter against the influences of flushing in the early period of operation or discharge of air in the piping as well as ease of maintenance and inspection work.
- Secure a space necessary for inspection, disassembling, etc. of the flow meter in the piping arrangement. Especially, secure a space for enabling disassembling of the measuring chamber of the flow meter.

#### Examples of piping installation

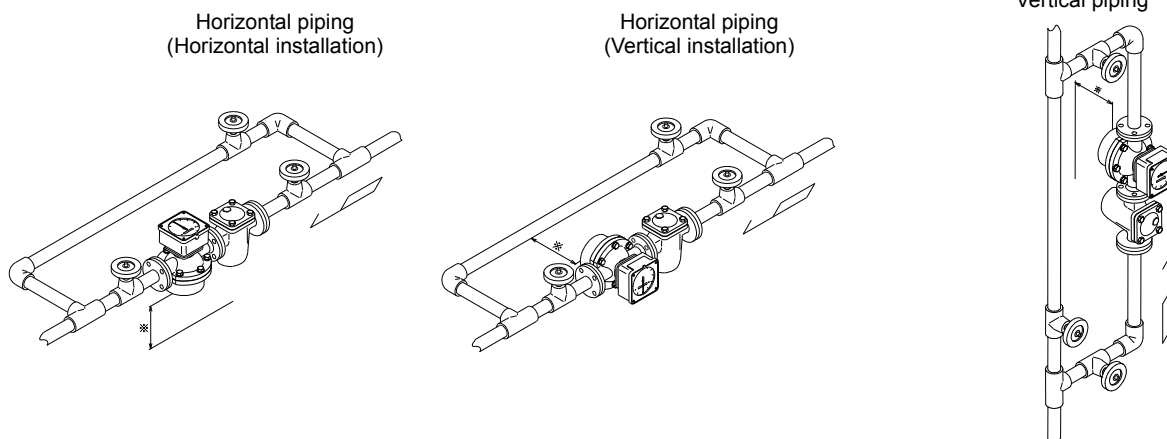

The mark ※ indicates a space necessary for disassembling and inspection.

Install the piping in a way to secure a dimension no small than the figures indicated on the table below.

Nominal size & volume symbol	Unit (mm)			
	025B0 040A0	040B0 050A0	050B0 080A0	080B0 100A0
※Dimension	192	246	312	444

### 8. Remote measurement system

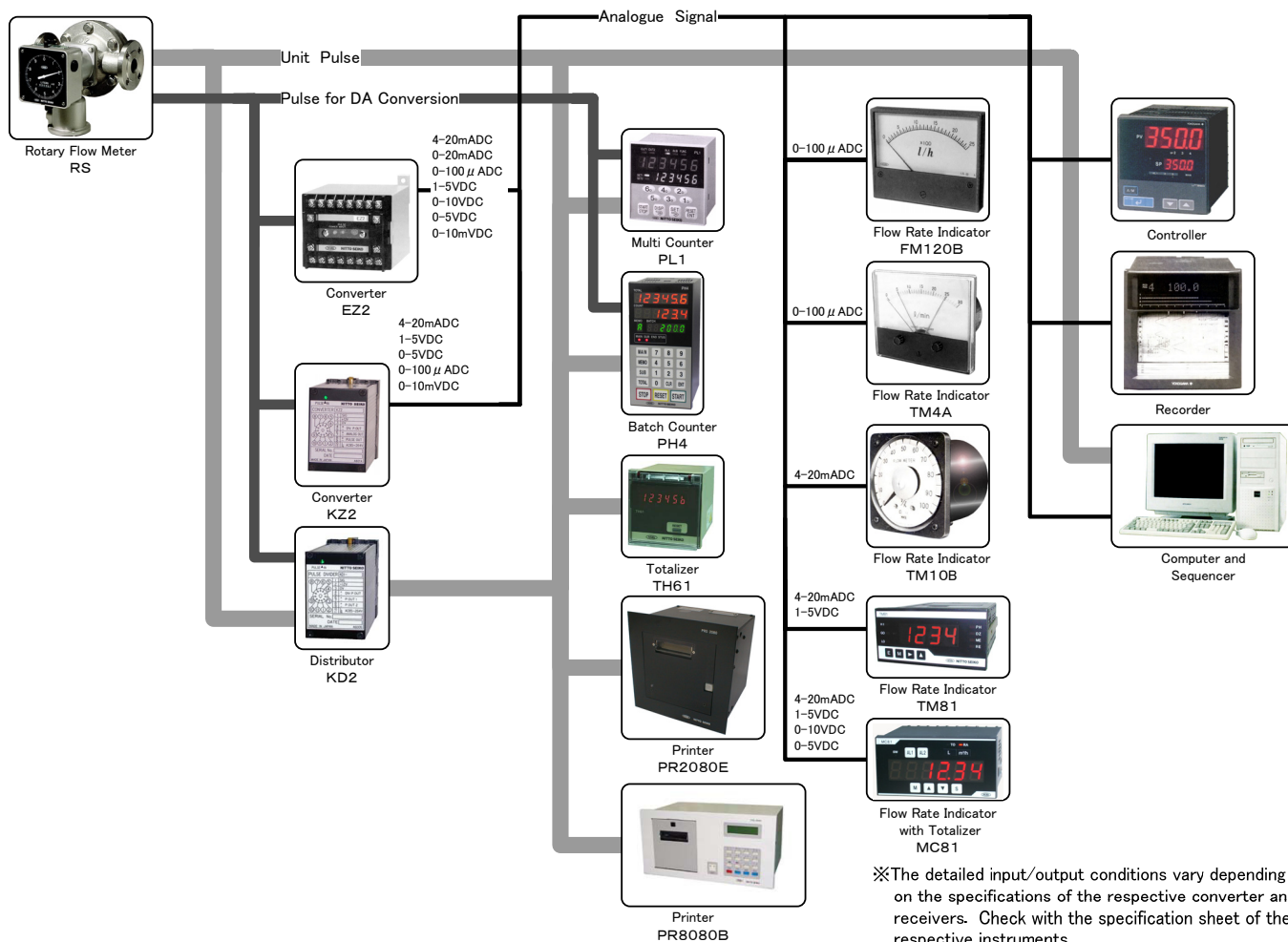

9. External dimensions (Unit : mm)

● Direct-reading type

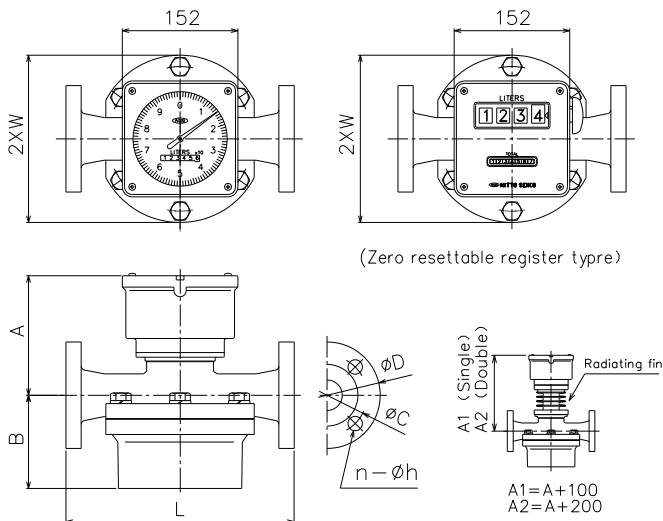

Nominal size symbol	Volume symbol	Flange standard	L	A	B	W	D	C	n	h	Weight (kg)
025B0	25	JIS10K	220	146	96	85	125	90	4	19	14
		JIS20K	224								15
040A0	40	JIS10K	300	146	96	85	140	105	4	19	16
		JIS20K	304								17
040B0	40	JIS10K	300	158	123	110	140	105	4	19	23
		JIS20K	304								24
050A0	50	JIS10K	370	158	123	110	155	120	4	19	24
		JIS20K	374								25
050B0	50	JIS10K	370	144	156	143	155	120	4	19	40
		JIS20K	374								42
080A0	80	JIS10K	400	144	156	143	185	150	8	19	43
		JIS20K	408				200	160			23
080B0	80	JIS10K	400	151	222	170	185	150	8	19	69
		JIS20K	408				200	160			23
100A0	100	JIS10K	460	151	222	170	210	175	8	19	72
		JIS20K	472				225	185			23

Note) 1. In case of single cooling fin, size is A + 100mm  
 In case of double cooling fin, size is A + 200mm  
 2. Shown weight is for material code FF (JIS10K) and DD (JIS20K).

● Instantaneous flow rate indicator type

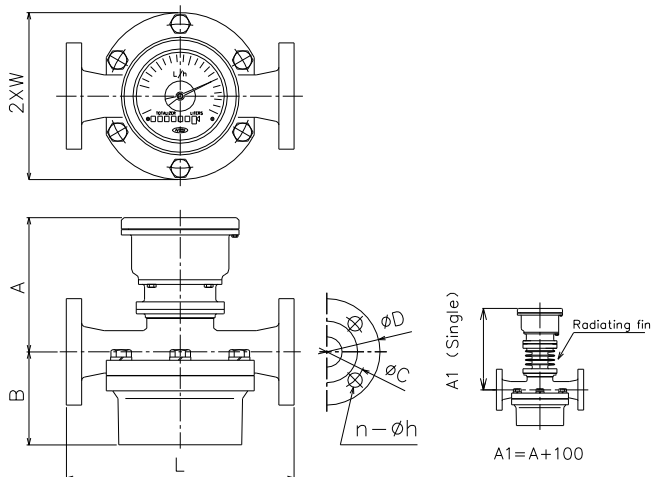

Nominal size symbol	Volume symbol	Flange standard	L	A	B	W	D	C	n	h	Weight (kg)
025B0	25	JIS10K	220	167	96	85	125	90	4	19	15
		JIS20K	224								16
040A0	40	JIS10K	300	167	96	85	140	105	4	19	17
		JIS20K	304								18
040B0	40	JIS10K	300	179	123	110	140	105	4	19	24
		JIS20K	304								25
050A0	50	JIS10K	370	179	123	110	155	120	4	19	25
		JIS20K	374								26
050B0	50	JIS10K	370	165	156	143	155	120	4	19	41
		JIS20K	374								43
080A0	80	JIS10K	400	165	156	143	185	150	8	19	44
		JIS20K	408				200	160			23
080B0	80	JIS10K	400	172	222	170	185	150	8	19	70
		JIS20K	408				200	160			23
100A0	100	JIS10K	460	172	222	170	210	175	8	19	73
		JIS20K	472				225	185			23

Note) 1. In case of single cooling fin, size is A + 100mm  
 2. Shown weight is for material code FF (JIS10K) and DD (JIS20K).

● Pulse generator type

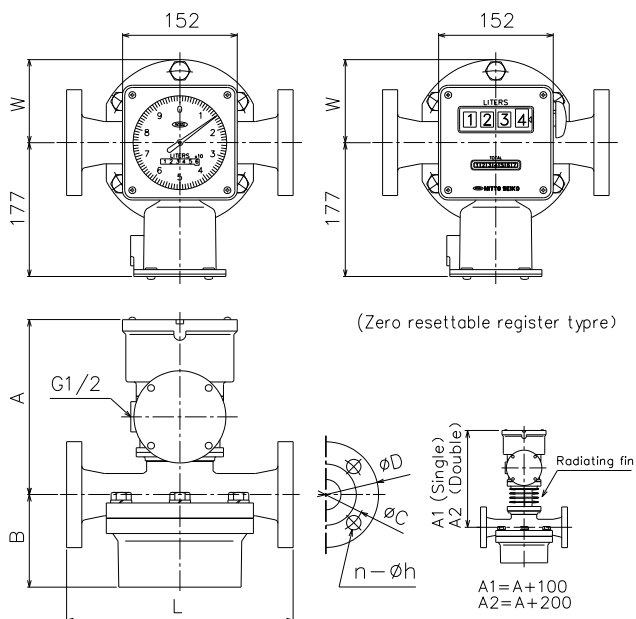

Nominal size symbol	Volume symbol	Flange standard	L	A	B	W	D	C	n	h	Weight (kg)
025B0	25	JIS10K	220	221	96	85	125	90	4	19	16
		JIS20K	224								17
040A0	40	JIS10K	300	221	96	85	140	105	4	19	18
		JIS20K	304								19
040B0	40	JIS10K	300	233	123	110	140	105	4	19	25
		JIS20K	304								26
050A0	50	JIS10K	370	233	123	110	155	120	4	19	26
		JIS20K	374								27
050B0	50	JIS10K	370	219	156	143	155	120	4	19	42
		JIS20K	374								44
080A0	80	JIS10K	400	219	156	143	185	150	8	19	45
		JIS20K	408				200	160			23
080B0	80	JIS10K	400	226	222	170	185	150	8	19	71
		JIS20K	408				200	160			23
100A0	100	JIS10K	460	226	222	170	210	175	8	19	74
		JIS20K	472				225	185			23

Note) 1. In case of single cooling fin, size is A + 100mm  
 In case of double cooling fin, size is A + 200mm  
 2. Shown weight is for material code FF (JIS10K) and DD (JIS20K).

●Explosion-protection type

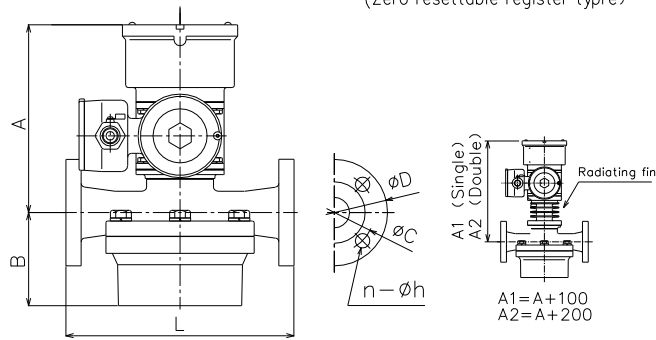
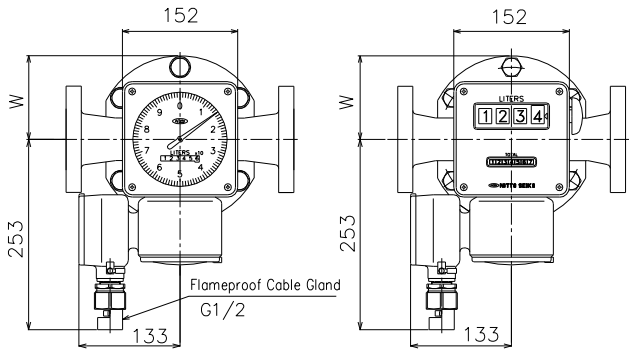

Nominal size symbol	Volume symbol	Flange standard	L	A	B	W	D	C	n	h	Weight (kg)
025B0	25	JIS10K	220	235	96	85	125	90	4	19	19
		JIS20K	224								20
040A0	40	JIS10K	300	235	96	85	140	105	4	19	21
		JIS20K	304								22
040B0	40	JIS10K	300	247	123	110	140	105	4	19	28
		JIS20K	304								29
050A0	50	JIS10K	370	247	123	110	155	120	4	19	29
		JIS20K	374								30
050B0	50	JIS10K	370	233	156	143	155	120	4	19	45
		JIS20K	374								47
080A0	80	JIS10K	400	233	156	143	185	150	8	19	48
		JIS20K	408				200	160			23
080B0	80	JIS10K	400	240	222	170	185	150	8	19	74
		JIS20K	408				200	160			23
100A0	100	JIS10K	460	240	222	170	210	175	8	19	77
		JIS20K	472				225	185			23

●Jacket type

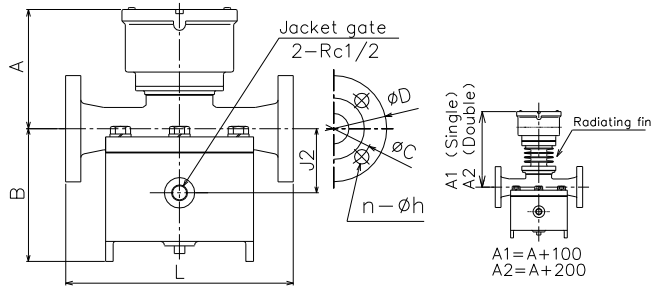
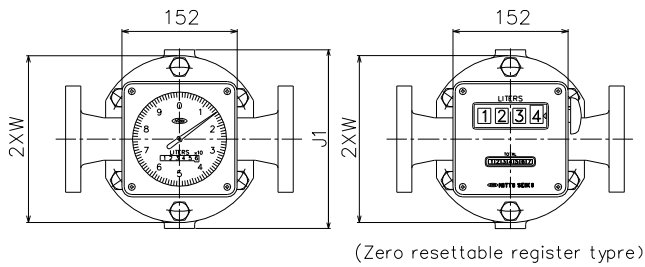

Nominal size symbol	Volume symbol	Flange standard	L	A	B	W	J 1	J 2	D	C	n	h	Weight (kg)
025B0	25	JIS10K	220	146	133	85	180	75	125	90	4	19	18
040A0	40	JIS10K	300	146	133	85	180	75	140	105	4	19	20
040B0	40	JIS10K	300	158	175	110	236	96	140	105	4	19	38
050A0	50	JIS10K	370	158	175	110	236	96	155	120	4	19	41
050B0	50	JIS10K	370	144	209	143	300	108	155	120	4	19	55
080A0	80	JIS10K	400	144	209	143	300	108	185	150	8	19	59
080B0	80	JIS10K	400	151	284	170	360	135	185	150	8	19	103
100A0	100	JIS10K	460	151	284	170	360	135	210	175	8	19	106

Note) 1. In case of single cooling fin, size is A + 100mm  
 In case of double cooling fin, size is A + 200mm  
 2. Above table is for material code S2.  
 3. Shown weight is for material code S2.

10. Product code

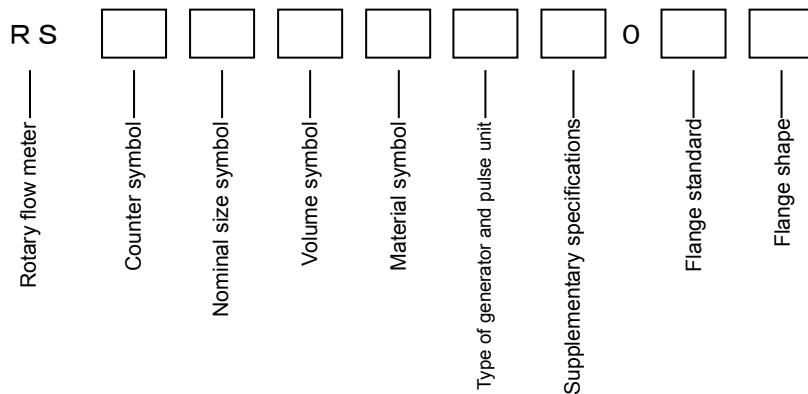

●: Standard; ○: Manufacturable; ×: Non-manufacturable

Type	Specification code	Specifications	025		040		050		080		100
			BO	AO	BO	AO	BO	AO	BO	AO	
RS		Rotary flow meter	●	●	●	●	●	●	●	●	●
Counter symbol	A0	Pointer and direct-reading type	●	●	●	●	●	●	●	●	●
	Z8	Zero resettable register type	○	○	○	○	○	○	○	○	○
	I0	With direct-reading instantaneous flow indicator	○	○	○	○	○	○	○	○	○
Nominal size symbol	025	Nominal size: 25A	●								
	040	Nominal size: 40A		●	●						
	050	Nominal size: 50A				●	●				
	080	Nominal size: 80A						●	●		
	100	Nominal size: 100A								●	●
Volume symbol	A0	Volume small		●		●		●		●	
	BO	Volume large	●		●		●		●		●
Material symbol	FB	Main body: FC200, Measuring chamber: CAC406, Rotor: PPS, GC, AC	●	●	●	●	●	●	●	●	●
	FF	Main body: FC200, Measuring chamber: FC200, Rotor: PPS, GC, AC	●	●	●	●	●	●	●	●	●
	F2	Main body: FC200, Measuring chamber: SCS14A, Rotor: PPS, GC, AC	●	●	●	●	●	●	●	●	●
	DB	Main body: FCD450, Measuring chamber: CAC406, Rotor: PPS, GC, AC	●	●	●	●	●	●	●	●	●
	DD	Main body: FCD450, Measuring chamber: FCD450, Rotor: PPS, GC, AC	●	●	●	●	●	●	●	●	●
	D2	Main body: FCD450, Measuring chamber: SCS14A, Rotor: PPS, GC, AC	●	●	●	●	●	●	●	●	●
	S2	Main body: SCS14A, Measuring chamber: SCS14A, Rotor: PPS, GC, AC	●	●	●	●	●	●	●	●	●
Type of generator and pulse unit	12	Without pulse output	●	●	●	●	●	●	●	●	●
	R3	Reed switch (contact) pulse 0.1L/p	○※1	○※1	○※1,※2	○※1,※2	×	×	×	×	×
	R4	Reed switch (contact) pulse 1L/p	○	○	○	○	○※1,※2	○※1,※2	○※1,※2	○※1,※2	○※1,※2
	R5	Reed switch (contact) pulse 10L/p	○	○	○	○	○	○	○	○	○
	R6	Reed switch (contact) pulse 100L/p	×	×	○※2	○※2	○	○	○	○	○
	R7	Reed switch (contact) pulse 1m3/p	×	×	×	×	○※2	○※2	○※2	○※2	○※2
	M2	High frequency (no-contact) pulse 0.01L/p	○	○	○※2	○※2	×	×	×	×	×
	M3	High frequency (no-contact) pulse 0.1L/p	○	○	○	○	○※2	○※2	○※2	○※2	○※2
	M4	High frequency (no-contact) pulse 1L/p	○	○	○	○	○	○	○	○	○
	M5	High frequency (no-contact) pulse 10L/p	×	×	○※2	○※2	○	○	○	○	○
	M6	High frequency (no-contact) pulse 100L/p	×	×	×	×	○※2	○※2	○※2	○※2	○※2
	MD	High frequency (no-contact) pulse DA conversion pulse	○	○	○	○	○	○	○	○	○
	K1	Photoelectric (no-contact) pulse 0.001L/p	○	○	○※2	○※2	×	×	×	×	×
K2	Photoelectric (no-contact) pulse 0.01L/p	○	○	○	○	○※2	○※2	○※2	○※2	○※2	
K3	Photoelectric (no-contact) pulse 0.1L/p	×	×	○※2	○※2	○	○	○	○	○	
Supplementary specifications ※3	345	Non-explosionproof & without radiating fins	●	●	●	●	●	●	●	●	●
	X00	Flameproof enclosure type	○	○	○	○	○	○	○	○	○
	X01	Flameproof enclosure type + Single-stage radiating fin	○	○	○	○	○	○	○	○	○
	X02	Flameproof enclosure type + Double-stage radiating fins	○	○	○	○	○	○	○	○	○
	001	Single-stage radiating fin	○	○	○	○	○	○	○	○	○
	002	Double-stage radiating fins	○	○	○	○	○	○	○	○	○
	00J	With jacket	○	○	○	○	○	○	○	○	○
	00W	With jacket + Radiating fin	○	○	○	○	○	○	○	○	○
Single-stage fin in the case where the liquid temperature exceeds 100°C, but not exceeds 150°C for counter symbol I0.											
Flange standard	005	JIS5K	○	○	○	○	○	○	○	○	○
	010	JIS10K	●	●	●	●	●	●	●	●	●
	016	JIS16K	○	○	○	○	○	○	○	○	○
	020	JIS20K	○	○	○	○	○	○	○	○	○
	AS1	ANSI class150	○	○	○	○	○	○	○	○	○
	AS3	ANSI class300	○	○	○	○	○	○	○	○	○
Flange shape	F	FF flange	●	○	○	○	○	○	○	○	○
	R	RF flange	○	●	●	●	●	●	●	●	●

Note) No explosion proof type is available in the photoelectric pulse generator type.

※1: It is available for manufacturing in case of less than 5P/s.

※2: It is available for manufacturing depend on volume per rev. of pointer. Please refer to the output pulse unit table.

※3: Some combination of specification code is not manufacturable.

Specification code	Specification	025BO~080AO						080BO, 100AO							
		FB	FF	F2	DB	DD	D2	S2	FB	FF	F2	DB	DD	D2	S2
00J	With jacket	×	○	○	×	×	○	○	×	×	○	×	×	○	○
00W	With jacket + Radiating fin	×	○	○	×	×	○	○	×	×	○	×	×	○	○



## 11. Strainer

To prevent foreign matters mixed in the liquid from penetrating into the flow meter to cause troubles, it is necessary to install a strainer immediately before the flow meter or at a point as close as possible to the inflow side. (Element mesh:60 TO 200 mesh)

◆◆◆ Matters to be specified at the time of ordering ◆◆◆

1. Type and specification code
2. Name of measured liquid, viscosity, temperature
3. Flow direction of fluid, mounting position

▶ The contents of description are subject to change without notice.



**NITTO SEIKO CO.,LTD.**

30 Nogamihata, Nobu-Cho, Ayabe, Kyoto 623-0041, JAPAN  
TEL : +81-773-43-1412  
FAX : +81-773-43-1595  
E-mail:sales@nittoseiko.co.jp  
<http://www.nittoseiko.co.jp/>