

SMALL SIZE ROTARY FLOW METER

SPECIFICATIONS

SSV10252 23.11

1. Outline

Small size rotary flow meter is a flow meter for measuring small flow rate of general liquid, characterized by its simple construction.

This flow meter, which can measure even highly viscous liquid easily with an extremely small pressure loss, is currently used for measurement control of liquid in almost all industries.

2. Features

- The Rotary Flow Meter always keeps high accuracy because it is unaffected by the viscosity and temperature of fluid in operation.
- By selecting different materials for different parts, most fluids can be measured.
- Having low pressure loss, the meter can be used for highly viscous fluids.
- By adding a pulse generator, the flow meter can be connected to various electrical instruments.



3. Specifications

Specifications of measuring unit

Nominal size		20		25	
Volume symbol		B	C	C	A
Measured fluid		Chemical solutions, food liquids, petroleum, water, etc.			
Nominal size		20A		25A	
Liquid viscosity		0.5~500 mPa·s (Special 500 ~30,000 mPa·s)			
Liquid temperature		0~200°C (special -20~200°C for Material symbol S2)			
Liquid pressure		2.0 MPa or under			
Measuring accuracy		Within ±0.5% or within ±0.2% Momentary flow rate Within ±2.0%FS			
Standard connection	Flange	JIS5K, 10K, 20K, ANSI class 150, 300 (For the details, see paragraph of "Process connection and face-to-face dimensions")			
Material	Material symbol	FB	Main body : FCD450, Head cover : FC200, Measuring chamber : CAC406, Rotor : GC, AC	Main body : FC200, Measuring chamber : CAC406, Rotor : GC, AC	
		FF	---	Main body : FC200, Measuring chamber : FC200, Rotor : GC, AC	
		F2	---	Main body : FC200, Measuring chamber : SCS14A, Rotor : GC, AC	
		DB	Main body : FCD450, Head cover : FCD450, Measuring chamber : CAC406, Rotor : GC, AC	---	
		DD	---	Main body : FCD450, Measuring chamber : FCD450, Rotor : GC, AC	
		D2	---	Main body : FCD450, Measuring chamber : SCS14A, Rotor : GC, AC	
		S2	Main body : SCS14A, Head cover : SCS14A, Measuring chamber : SCS14A, Rotor : GC, AC	Main body : SCS14A, Measuring chamber : SCS14A, Rotor : GC, AC	
FC200: Cast iron; FCD450: Ductile cast iron; CAC406: Cast bronze; SCS14A: Stainless steel casting GC: Carbon; AC: Corrosion-resistant aluminum. (10mPa.s and over) Nominal size 20A has material symbol S2 only for an approved for high-pressure gas use					
Material & Permissible Pressure		Nominal Pressure	Flange standard	Material symbol	Permissible Pressure (Liquid Temp.~200°C) MPa
		5K	JIS5K	FB/FF/F2	0.5
		10K	JIS10K, ANSI class150	DB/DD/D2/S2	1.0
		20K	JIS20K, ANSI class300	DB/DD/D2/S2	2.5
Jacket specifications		Thermal liquid (Hot water, Steam) pressure is 0.5MPa or less. Permissible Temp. 200°C, Permissible Pressure 1.0MPa			
Special specifications		Article approved for high-pressure gas service: Only material symbol S2 is manufacturable. Liquid temperature -10~75°C			

Specifications of counter unit

Nominal size			20		25	
Volume symbol			B	C	C	A
Types			Pointer type (A), Zero resettable register type (Z), Instantaneous flow rate indicator type (I)			
Indication	Pointer type (A)	Pointer Dial plate	Dial unit	0.01 L		0.1 L
			Volume per rev	1 L		10 L
		Total counter	Dial unit	1 L		10 L
			Number of digits	5 (99,999L)		5 (99,999 x 10L)
	Zero resettable register type (Z)	Pointer Dial plate	Dial unit	0.01 L		0.1 L
			Volume per rev	1 L		10 L
		Continuous total counter	Dial unit	1 L		10 L
			Number of digits	5 (99,999L)		5 (99,999 x 10L)
	Instantaneous flowrate indicator type (I)	Pointer Dial plate	Dial unit	--		50 L/h
			Full scale	--		320~1600 L/h
Total counter		Dial unit	--		0.1 L	
		Number of digits	--		7 (999,999.9L)	

Output	Pulse output	Unit pulse	Type of signal	(Note) Either one of (1) voltage no-contact signal (high frequency type, photoelectric type), or (2) reed switch contact signal.
			Output unit	No-contact pulse output : See "No-contact pulse output" table. Contact pulse output : See "Contact pulse output" table.
		DA conversion pulse	Available for no-contact pulse output.	
		(Note) No simultaneous output of unit pulse and DA conversion pulse can be made.		
	Analogue output	Unavailable for direct output. (External converter is required)		
Power source		The following external power sources are required, for outputting voltage no-contact signals: (1) High frequency type pulse generator: 6~26.4VDC, 23mA (at 24V DC), 17 mA (at 12V DC). (2) Photoelectric type pulse generator: 12VDC, 50mA		
Ambient temperature		-10~60°C, For explosion-proof type, -10 to 40°C		
Explosion-protection		Flameproof enclosure type d2G4 : Only for reed switch pulser.		
Radiating fin		Single-stage fin in the case where the liquid temperature exceeds 130°C, and double-stage fins in the case where the liquid temperature exceeds 180°C. Instantaneous flow indicator type: Single-stage fin in the case where the liquid temperature exceeds 100°C but not exceeds 150°C		
Material		Aluminum die casting, Plastic		

Output pulse unit table (Optional)

No-contact output pulse unit table (● Photoelectric type, ○: High frequency type)

Nominal size & volume symbol	One rev. of pointer	Pulse unit				
		1mL/P	10mL/P	100mL/P	1L/P	10L/P
20B	1L	○	○	--	--	--
20C	1L	○	○	○	--	--
25C	1L	○	○	--	--	--
	10L	●	○	○	○	--
25A	1L	--	○	--	--	--
	10L	●	○	○	○	--

Contact output pulse unit table (○ Reed switch)

Nominal size & volume symbol	One rev. of pointer	Pulse unit				
		1mL/P	10mL/P	100mL/P	1L/P	10L/P
20B	1L	--	○	○	○	--
20C	1L	--	○	○	○	--
25C	10L	--	--	○	○	○
25A	10L	--	--	○	○	○

- High frequency pulse generator (Symbol : M)

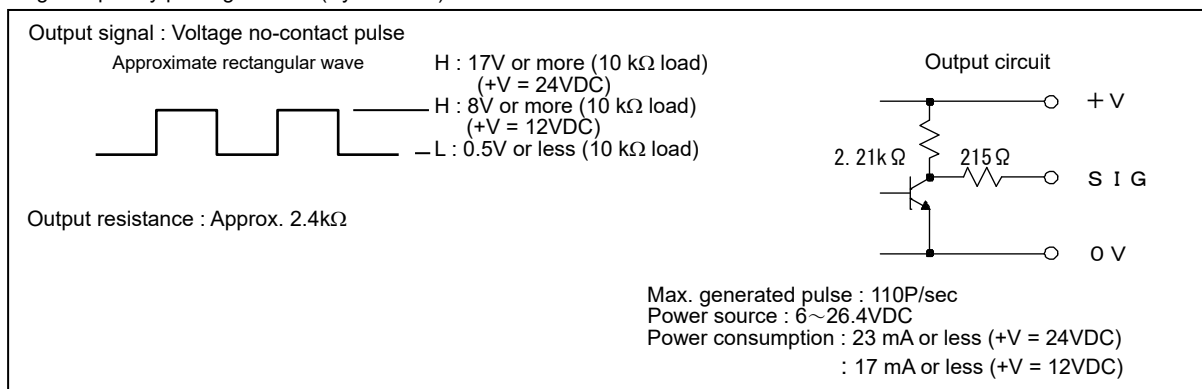

- Photoelectric pulse generator (Symbol : K)

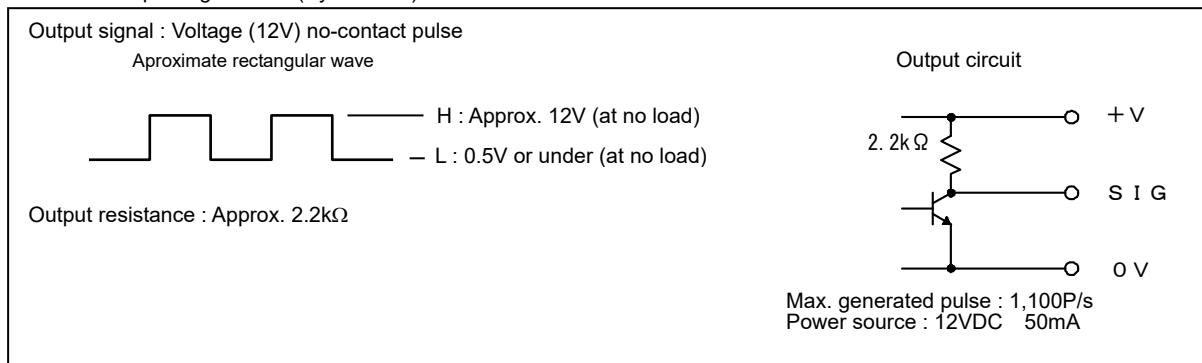

- Reed switch pulse generator (Symbol : R)

Type	Output signal	Max. voltage	Max. current	Switch capacity	Contact resistance	Max. generated pulse
DRR-5	No-voltage contact pulse	200V AC·DC	1A	25W	0.06 Ω	5P/s
MR506	No-voltage contact pulse	50V DC	250mA	15W	0.1 Ω	5P/s

4. Range of flow rate (L/h)

- Pointer type(A), Zero resettable register type(Z)

Nominal size & volume symbol	Viscosity							
	0.5 mPa·s~	1 mPa·s~	2 mPa·s~	4 mPa·s~	10 mPa·s~	50 mPa·s~	100 mPa·s~	~500 mPa·s
Liquid	Gasoline	Water (normal temp.)	Kerosene	Light oil	Heavy oil A	Heavy oil B	Heavy oil C	
20B	50~200	—	50~200	35~200	25~200	10~200	5~200	
20C	80~400	—	60~400	50~400	40~400	20~400	10~400	
25C	250~800	200~800	160~800	100~800	80~800	30~800	15~800	
25A	300~1,600	300~1,600	160~1,600	100~1,600	80~1,600	30~1,600	15~1,600	

- Pulse generator

Nominal size & volume symbol	Viscosity							
	0.5 mPa·s~	1 mPa·s~	2 mPa·s~	4 mPa·s~	10 mPa·s~	50 mPa·s~	100 mPa·s~	~500 mPa·s
Liquid	Gasoline	Water (normal temp.)	Kerosene	Light oil	Heavy oil A	Heavy oil B	Heavy oil C	
20B	60~200	—	50~200	40~200	30~200	15~200	5~200	
20C	80~400	—	60~400	50~400	40~400	20~400	10~400	
25C	250~800	200~800	160~800	100~800	80~800	30~800	15~800	
25A	300~1,600	300~1,600	160~1,600	100~1,600	80~1,600	30~1,600	15~1,600	

(Note) 1. The above table indicates the range of standard flow rate using carbon (10 mPa·s or less) and aluminium alloy (10 mPa·s and over) for the rotor material.

2. Please select the type of which 40~60% of Max. flow rate is as same as operation flow rate.

5. Pressure loss

Nominal size & volume symbol : 2 0 B ~ 2 5 A

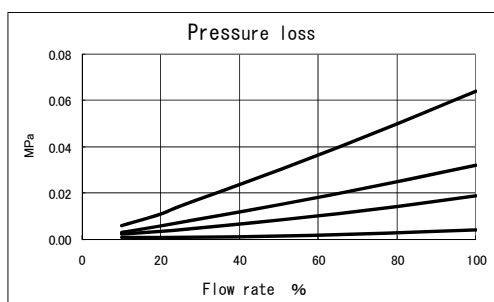

500 mPa·s

100 mPa·s

50 mPa·s

1 mPa·s

Nominal size & volume symbol	100%Flow rate
20B	200L/h
20C	400L/h
25C	800/h
25A	1600L/h

6. Process connection and face-to-face dimensions (Unit : mm)

Nominal size & volume symbol	Material symbol	JIS			ANSI	
		5K	10K	20K	class150	class300
20B	FB	160	160	--	160	--
	DB	160	160	168	160	168
	S2	160	160	164	160	164
20C	FB	160	160	--	160	--
	DB	160	160	168	160	168
	S2	160	160	164	160	164
25C	FB/FF/F2	192	200	--	200	--
	DD/D2	192	200	204	200	208
	S2	192	200	204	200	208
25A	FB/FF/F2	200	200	--	200	--
	DD/D2	200	200	204	200	208
	S2	192	200	204	200	208

7. Piping method

- Install a strainer on the inlet side of the flow meter without fail. To avoid outflow to the downstream side due to damage of internal component parts, install a strainer also on the outlet side of the flow meter. (Note) The standard mesh of the strainer element is 60 meshes.
- Install a bypass piping. In designing this bypass piping, take account of protection of the inner elements of the flow meter against the influences of flushing in the early period of operation or discharge of air in the piping as well as ease of maintenance and inspection work.
- Secure a space necessary for inspection, disassembling, etc. of the flow meter in the piping arrangement. Especially, secure a space for enabling disassembling of the measuring chamber of the flow meter.

Examples of piping installation

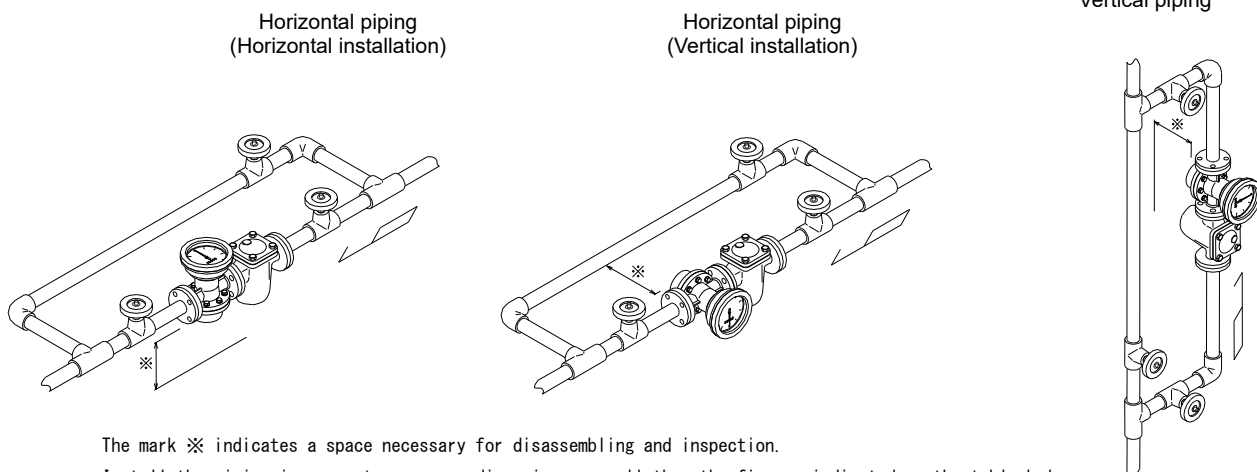

The mark ※ indicates a space necessary for disassembling and inspection.

Install the piping in a way to secure a dimension no small than the figures indicated on the table below.

Unit (mm)

Nominal size & volume symbol	25C	25A
※Dimension	146	162

Note) Nominal size 20A is combined unit of measuring chamber and flange. ※ mark space is not required.

8. Remote measurement system

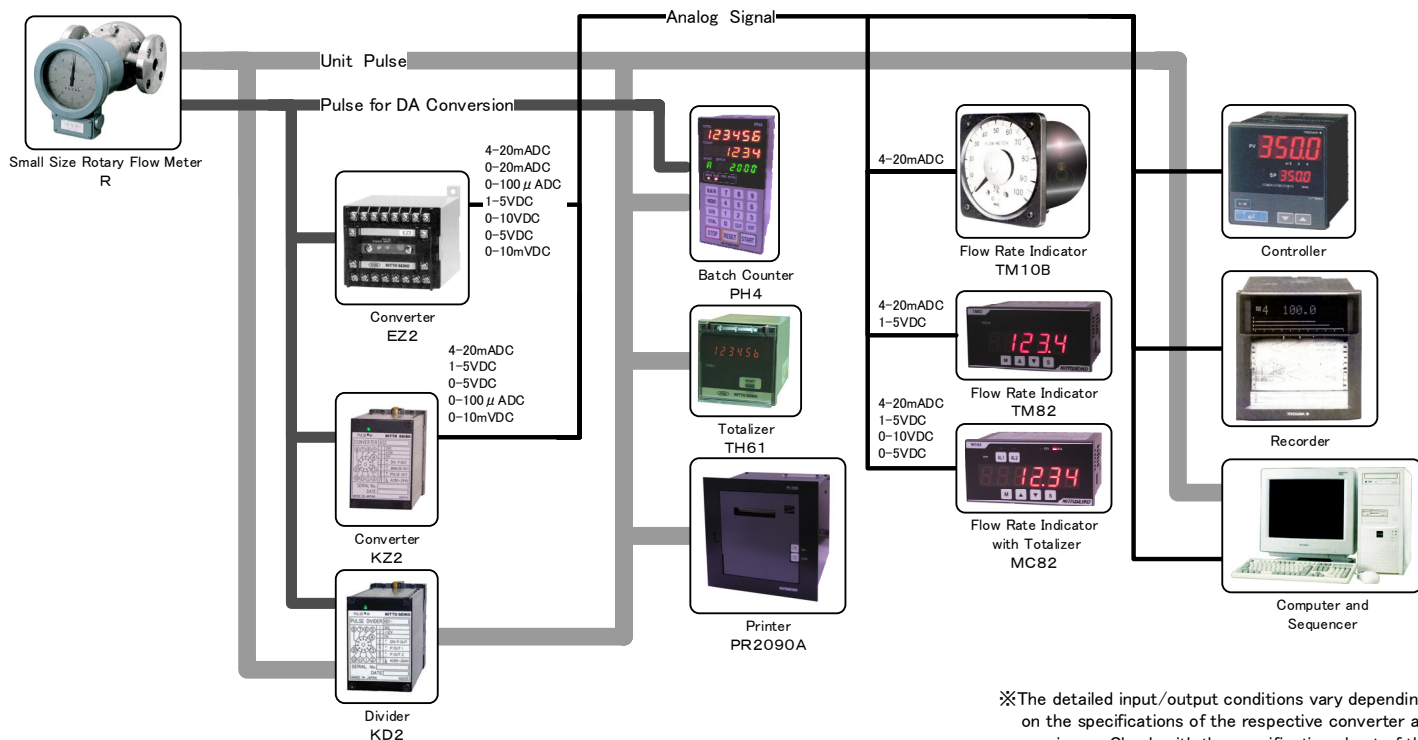

※The detailed input/output conditions vary depending on the specifications of the respective converter and receivers. Check with the specification sheet of the respective instruments.

9. External dimensions (Unit : mm)

● Direct-reading type Zero resettable type

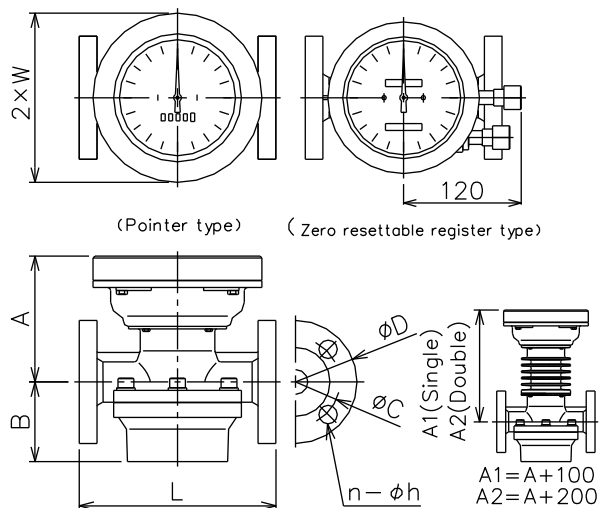

Nominal size & volume symbol	Nominal size	Flange standard	L	A	B	W	D	C	n	h	Weight (kg)
20B	20	JIS10K	160	198 (196)	52	86 (77)	100	75	4	15	8.3
		JIS20K	168								8.5
20C	20	JIS10K	160	198 (196)	52	86 (77)	100	75	4	15	8.2
		JIS20K	168								8.4
25C	25	JIS10K	200	134 (132)	73	87 (77)	125	90	4	19	9.0
		JIS20K	204								9.6
25A	25	JIS10K	200	128 (126)	81	87 (77)	125	90	4	19	11.0
		JIS20K	204								11.8

- Note) 1. Diameter W for general indication unit may be size in () depend on the material.
 2. In case of single-stage fin, size is A + 100mm
 In case of double-stage fins, size is A + 200mm
 3. Shown weight is for material code FB/FF (JIS10K) and DB/DD (JIS20K).
 4. A shape in the drawing is for nominal size 25A.

● Pulse generator type

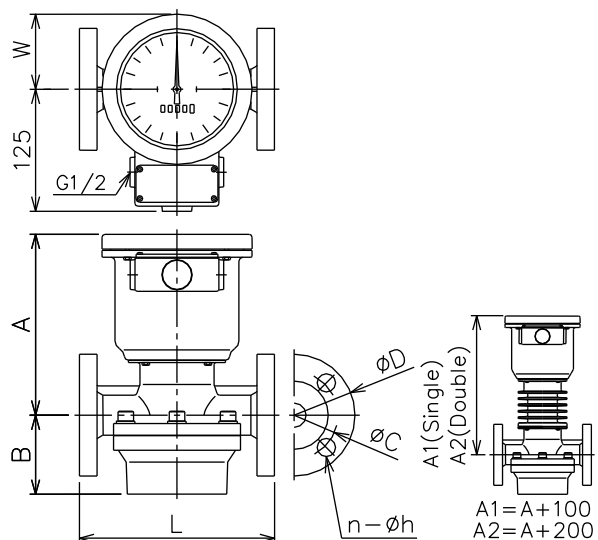

Nominal size & volume symbol	Nominal size	Flange standard	L	A		B	W	D	C	n	h	Weight (kg)
				Reed switch pulse generator	High frequency/Photoelectric pulse generator							
20B	20	JIS10K	160	198	258	52	77	100	75	4	15	9.5
		JIS20K	168									9.7
20C	20	JIS10K	160	198	258	52	77	100	75	4	15	9.4
		JIS20K	168									9.6
25C	25	JIS10K	200	131	191	73	77	125	90	4	19	10.2
		JIS20K	204									10.8
25A	25	JIS10K	200	126	186	81	77	125	90	4	19	12.2
		JIS20K	204									13.0

- Note) 1. Size "A" may differ by the pulser.
 2. In case of single-stage fin, size is A + 100mm
 In case of double-stage fins, size is A + 200mm
 3. Shown weight is high frequency pulser type with material FB/FF (JIS 10K) or DB/DD (JIS20K).
 4. A shape in the drawing is for nominal size 25A with high frequency pulser type.

● Instantaneous flow rate indicator type

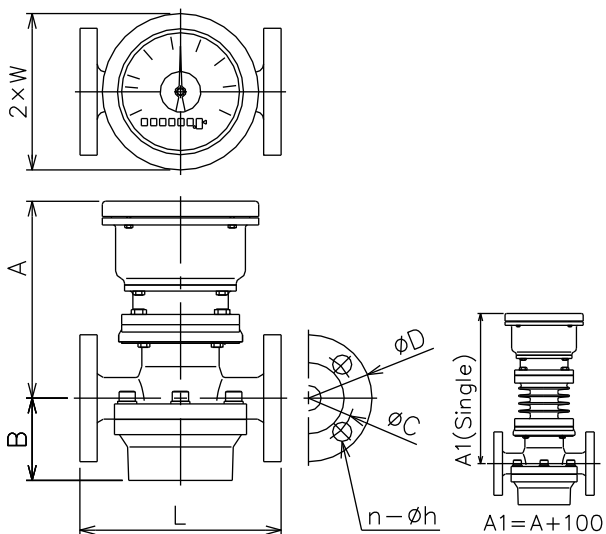

Nominal size & volume symbol	Nominal size	Flange standard	L	A	B	W	D	C	n	h	Weight (kg)
25A	25	JIS10K	200	190	81	77	125	90	4	19	12.0
		JIS20K	204								12.8

- Note) 1. In case of single-stage fin, size is A + 100mm
 2. Shown weight is for material code FB/FF (JIS10K) and DD (JIS20K).

●Explosion-protection type

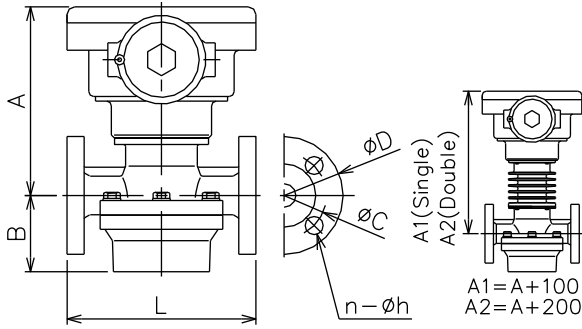
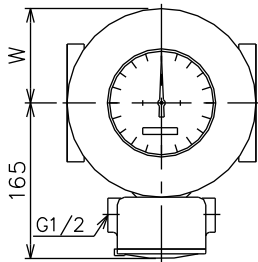

Nominal size & volume symbol	Nominal size	Flange standard	L	A	B	W	D	C	n	h	Weight (kg)
20B	20	JIS10K	160	272	52	77	100	75	4	15	13.8
		JIS20K	168								14.0
JIS10K		160	13.7								
JIS20K		168	13.9								
20C	25	JIS10K	200	205	73	100	125	90	4	19	14.5
JIS20K		204	15.1								
25A	25	JIS10K	200	200	81	100	125	90	4	19	16.5
		JIS20K	204								17.3

Note) 1. In case of single-stage fin, size is A + 100mm
 In case of double-stage fins, size is A + 200mm
 2. Shown weight is for material code FB/FF (JIS10K) and DB/DD (JIS20K).
 3. Shape of drawing is for nominal size 25A.

●Jacket type

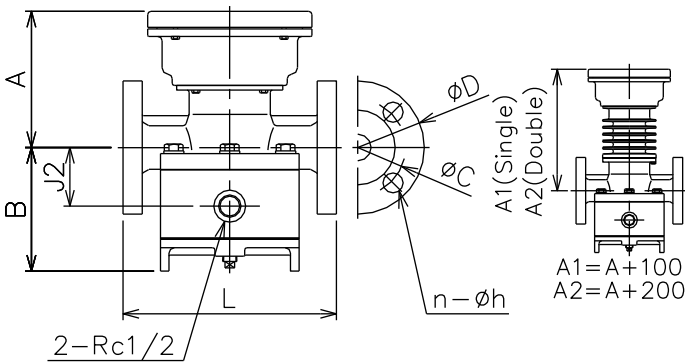
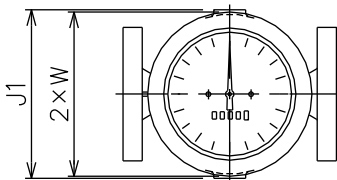

Nominal size & volume symbol	Nominal size	Flange standard	L	A	B	W	J1	J2	D	C	n	h	Weight (kg)
20B	20	JIS10K	180	308	52	77	142	8	100	75	4	15	13.0
		JIS20K											
JIS10K		160											
JIS20K		168											
20C	25	JIS10K	200	132	106	77	138	51	125	90	4	19	14.0
JIS20K		204											
25A	25	JIS10K	200	126	115	77	158	55	125	90	4	19	14.0
JIS20K		204											

Note) 1. In case of single-stage fin, size is A + 100mm
 In case of double-stage fins, size is A + 200mm
 2. Shown weight is for material code S2.
 3. Shape of drawing is for nominal size 25A.

10. Product code

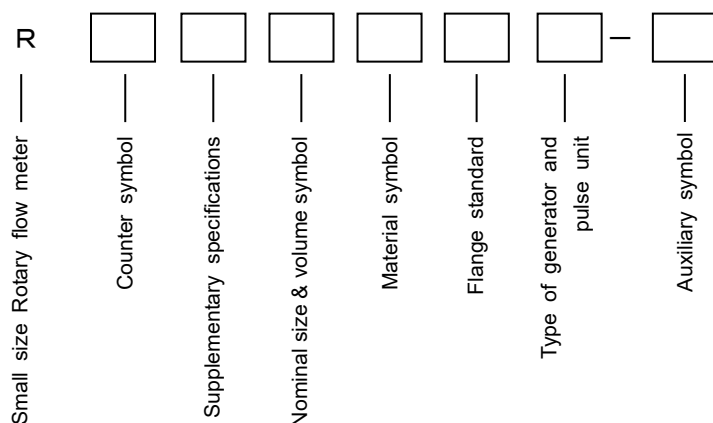

●: Standard; ○: Manufacturable; ×: Non-manufacturable

Type	Specification code	Specifications	20B	20C	25C	25A
R		Small size rotary flow meter	●	●	●	●
Counter symbol	A	Pointer type	●	●	●	●
	C	Unit pulse type	○	○	○	○
	H	DA conversion pulse type	○	○	○	○
	Z	Zero resettable register type	○	○	○	○
	I	Instantaneous flow indicator type	×	×	×	○
Supplementary specifications		Without Supplementary	●	●	●	●
	F	Radiating fin	○	○	○	○
	X	Flameproof enclosure type ※2	○	○	○	○
	J	With jacket	○	○	○	○
	W	With jacket + Radiating fin	○	○	○	○
	FX	Flameproof enclosure type ※2 + radiating fin	○	○	○	○
	XJ	Flameproof enclosure type ※2 + With jacket	○	○	○	○
	XW	Flameproof enclosure type ※2 + With jacket + radiating fin	○	○	○	○
Single-stage fin in the case where the liquid temperature exceeds 130°C, and double-stage fins in the case where the liquid temperature exceeds 180°C. Instantaneous flow indicator type: Single-stage fin in the case where the liquid temperature exceeds 100°C but not exceeds 150°C						
Nominal size & Volume symbol	20B	Nominal size : 20A	●			
	20C	Nominal size : 20A		●		
	25C	Nominal size : 25A			●	
	25A	Nominal size : 25A				●
Material symbol	FB	For the details, see paragraph of "Specifications of measuring unit and Material "	●	●	●	●
	FF		×	×	●	●
	F2		×	×	●	●
	DB		●	●	×	×
	DD		×	×	●	●
	D2		×	×	●	●
	S2		○	○	●	●
Flange standard	05	JIS5KFF	○	○	○	○
		JIS10KFF	●	●	●	●
	20	JIS20KFF	○	○	○	○
	AS1	ANSI class150 RF	○	○	○	○
	AS3	ANSI class300 RF	○	○	○	○
Type of generator and pulse unit <small>Note) The pulse units available for output are restricted depending on: (1) pointer, and (2) type of generator. Refer to "Output Pulse Unit Table".</small>		Without pulse output	●	●	●	●
	R2	Reed switch (contact) pulse 0.01L/p	○	○	×	×
	R3	Reed switch (contact) pulse 0.1L/p	○	○	○	○
	R4	Reed switch (contact) pulse 1L/p	○	○	○	○
	R5	Reed switch (contact) pulse 10L/p	×	×	○	○
	M1	High frequency (no-contact) pulse 0.001L/p	○	○	○※1	×
	M2	High frequency (no-contact) pulse 0.01L/p	○	○	○	○
	M3	High frequency (no-contact) pulse 0.1L/p	×	○	○※1	○※1
	M4	High frequency (no-contact) pulse 1L/p	×	×	○※1	○※1
K1	Photoelectric (no-contact) pulse 0.001L/P	×	×	○※1	○※1	
Auxiliary symbol		Without auxiliary symbol	●	●	●	●
	Z06	Zero resettable register type	○	○	○	○

Note) 1. Omit symbol if the column of specification code is blank.

2. When you selected the counter symbol "H", select "Without pulse generator" for both type of transmitter and pulse unit.

3. When select "Z" for symbol of counter unit, add "Z06" as supplementary symbol.

※1 : It is available for manufacturing depend on volume per rev. of pointer. Please refer to the output pulse unit table.

※2 : Flame proof enclosure is available only in case of reed switch pulse output.

11. Strainer

To prevent foreign matters mixed in the liquid from penetrating into the flow meter to cause troubles, it is necessary to install a strainer immediately before the flow meter or at a point as close as possible to the inflow side.
(60~200Mesh)

◆◆◆ Matters to be specified at the time of ordering ◆◆◆

1. Type and specification code
2. Name of measured liquid, viscosity, temperature
3. Flow direction of fluid, mounting position

▶ The contents given here are subject to change without notice.

NITTOSEIKO CO.,LTD.

30 Nogamibata, Nobu-Cho, Ayabe, Kyoto 623-0041, JAPAN

TEL : +81-773-43-3151(Domestic Operation)
+81-6-6105-5086(Global Sales Section)

FAX : +81-773-43-3155

E-mail:sales@nittoseiko.co.jp

<https://www.nittoseiko.co.jp/en.html>