

Electronic Flow Meter for Oil

Oil Eye[®]

SPECIFICATIONS

SSV11151 25.07

1. Outline

Electronic flow meter for oil is a flow meter for oil & non-corrosive liquid realized by loading an electronic indicating & counting unit on the measuring unit of a rotary piston type positive displacement flow meter.

This electronic flow meter for oil is equipped with a "user setting function" which enables the user to make setting easily in the field, and can be used for a wide variety of applications.

This flow meter is available for measurement and control of feed oil to boilers, fuel oil, non-corrosive medium and high viscosity liquid, etc.



2. Features

- Simple construction with only measuring unit as mechanical structure
- Setting mode in the field is possible by button operation on the counting unit.
- Easy maintenance in the field by simulation output
- No need of any external power supply in the case of the field indication only.
- Available placing the batch system only with valve (Batch type only)

3. Specifications

Measuring unit

Nominal size & volume symbol		15L	20S	20M	20L	25L	40L
Measured liquid		Kerosene, light oil, heavy oil A/B/C, non-corrosive mid or high viscos liquid.					
Nominal size		15A	20A			25A	40A
Liquid viscosity		2~1,000mPa·s					
Liquid temperature		0~80°C (Up to 120°C for high temperature specification)					
Liquid pressure		1.0MPa or less					
Measuring accuracy		Within ±0.5%					
Standard connection		JIS10K FFFlange					
Material	Material symbol	Body : FC200, Body cover : AC2A, (Material is A5052 in case of selecting 15L of nominal size & volume symbol), Rotor : AC3A, Eccentric bearing:C3604BD					
	FB	FC200 : Cast iron, AC2A, AC3A : Aluminum casting alloy, A5052 : Aluminum casting, C3604BD : Free-cutting brass					

Counting unit

Nominal size & volume symbol		15L	20S	20M	20L	25L	40L	
Kind of type		Pulse & alarm output type, Analogue output type, Batch type (For AC or 24V DC)						
Indication	Display unit	Numerical indication : 7-segment LCD 5W x 10H, 8 digits, mode and alarm indication : LCD 2H						
	Indication item	Integrated flow rate	Integrated flow rate : 8 digits (MODE1)				Resettable integrated flow rate : 8 digits (MODE4)	
			For Pulse & alarm output type and analogue output type				Batch counter : 6 digits (MODE4)	
		Min. unit	0.01L~1m ³			0.1L~1m ³		
		Momentary flow rate	Momentary flow rate (/h) : 4 1/2 digits (MODE2), Momentary flow rate (/min) : 4 1/2 digits (MODE3)				Momentary flow rate (%) : 4 digits (MODE5)	
			Min. unit /h	0.1L/h~0.01m ³ /h			1L/h~0.1m ³ /h	
	Min. unit /min	1mL/min~0.1L/min			0.01L/min~1L/min			
	Note 1: Either one of "/h" or "/min" can be indicated. It should be selected by setting.							
	Alarm		Alarm for upper limit flow rate (HIGH), alarm for lower limit flow rate (LOW), battery alarm (BATT).					
	Note 2: Bothe integrated flow rate and momentary flow rate cannot be indicated simultaneously.							
Note 3: Indication item can be changed by pressing the "MODE" button located on the front of the counting unit.								
Output	No. of output	2 points						
	Output assignment	To each of SIG1 and SIG2, one is selected and assigned from among the respective outputs of "Unit pulse", "Unitless pulse", "Alarm for upper limit", "Alarm for lower limit", "Alarm for upper and lower limit" and "Battery alarm"						
	Type of signal	Voltage no-contact output or open collector output						
		Voltage no-contact :			Open collector :			
		Signal level H: Approx. equal to voltage of external power (at no load) (Approx. 24V DC for Batch type) L: 0.5V or less (at no load) Voltage & current : 27V DC, 30mA Voltage at ON : 0.5V or less Output resistance : Approx. 2.3kΩ (short circuit protection resistance : Approx. 100Ω)						
	Signal logic	Positive or negative logic Positive logic : Logic 1 at H (Transistor : OFF) Negative logic : Logic 1 at L (Transistor : ON)						
	Unit pulse	0.01L/P~1m ³ /P				0.1L/P~1m ³ /P		
	Unitless pulse	2.3mL	2.3mL	4.2mL	9.2mL	35.0mL	94.0mL	
	Pulse signal width	0.5~20ms or 5~200ms						
	Analogue output type	No. of output	1 point					
Output assignment		Momentary flow rate						
Type of signal		4~20mA DC						
Conversion accuracy		±0.5% (Full scale)						
Resolution		1/1000						
Allowable load resistance	500Ω or less							

Nominal size & volume symbol		015L0	020S0	020M0	020L0	025L0	040L0		
Output	Analog output type	No. of outputs	1 point						
		Output assignment	Flow rate						
		Kind of signal	4 ~ 20mA DC						
		Conversion accuracy	±0.5% (Full scale)						
		Resolution	1/1,000						
		Allow able load resistance	500Ω or less						
	Batch type	No. of outputs	4 points						
		Output assignment	SIG1, SIG2: To each of SIG1 and SIG2, one is selected and assigned from among the respective outputs of Unit pulse, Unitless pulse, Upper limit alarm, Lower limit alarm, and Upper and lower limit alarm. Control output: Metering signal 1, Metering signal 2						
		Kind of signal	Pulse output, alarm signal ; Refer to type of signal at articl of pulse & alarm signal.		Control output ; AC type			Control output ; 24V DC type	
			Metering signal 1 : Voltage no-contact, Triac Output voltage Approx, equal to external power voltage Load current 0.5A Metering signal 2 : No-voltage contact Contact capacity 250V AC / 2A, 30V DC / 2A		Metering signal 1 : Voltage contact Output voltage Approx, equal to external power voltage Load current 2A Metering signal 2 : No-voltage contact Contact capacity 250V AC / 2A, 30V DC / 2A				
Note 4: Either one of Pulse & alarm output or Analog output is available. Please select type when placing order.									
Note 5: All output type require external power supply.									
Power	Field indication only	Built-in lithium battery (3.6V DC ; Service life 5 years) Vary from use conditions.							
	Pulse & alarm output type	External power supply is required. Voltage 12~24V DC±10%, Current consumption Approx. 25mA (at 12V DC) / Approx. 38mA (at 24V DC)							
	Analog output type	External power supply is required. Voltage 24V DC±10%, Current consumption Approx. 22mA							
	Batch type	AC type : External power supply is required, Voltage 100~220V AC±10% 50/60Hz, Current consumptoin Approx.50mA (Except for current consumption of Metering signal 1)							
24V DC type : External power supply is required Voltage 24V DC ±10%, Current consumption Approx. 120mA (Except for current consumption of Metering signal 1)									
Ambient temperature		-10~60°C							
Explosion proof		Non-explosion proof							
Water proof		JIS C 0920 water proof (Except for Batch type)							
Material		Aluminum die casting (Except for Batch type)							

※1: "Battery alarm is only for the flow meter with battery.

4. Flow range (Unit: L/h)

Nominal size & volume symbol	2mPa·s ~	10mPa·s ~	50mPa·s ~	100mPa·s ~	500~1,000mPa·s
	Kerosene/Light oil	Heavy oil A	Heavy oil B	Heavy oil C	
015L0,020S0	40~200	30~200	20~200	10~200	10~160
020M0	60~400	40~400	25~400	15~400	15~320
020L0	100~1,000	50~1,000	40~1,000	20~1,000	20~800
025L0	250~2,500	100~2,500	60~2,500	40~2,500	40~2,000
040L0	600~6,000	250~6,000	150~6,000	100~6,000	100~4,800

Note: When selecting a model of flow meter, please select it so that normal flow range is 40~60% of its Max. flow.

5. Pressure loss

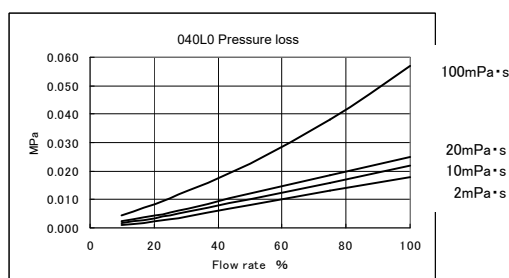
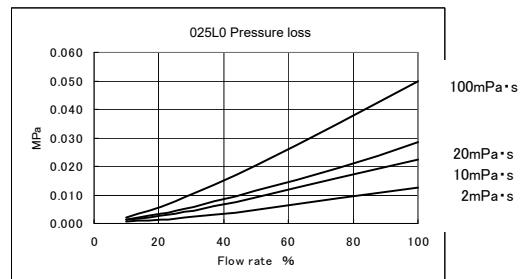
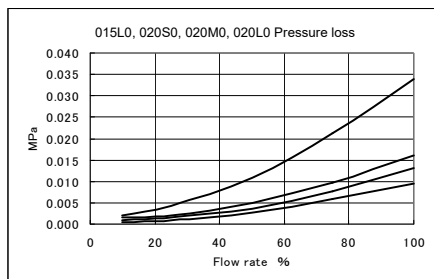

Nominal size & Volume symbol	100% flow rate
015L0,020S0	200L/h
020M0	400L/h
020L0	1,000L/h
025L0	2,500L/h
040L0	6,000L/h

6. Remote measurement system

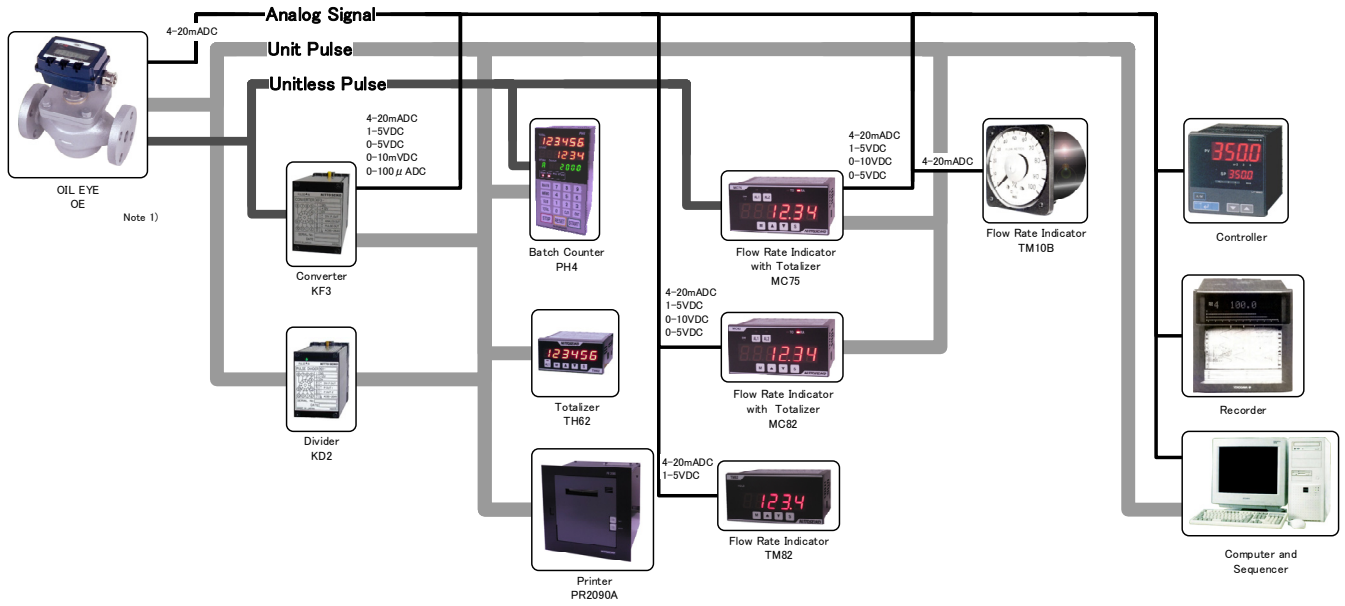

Note 1) For the analog output type.
The power supply is separately necessary excluding MC82, TM82.

※The detailed input/output conditions vary depending on the specifications of the respective converter and receivers. Check with the specification sheet of the respective instruments.

7. External dimensions (Unit: mm)

Field indication type

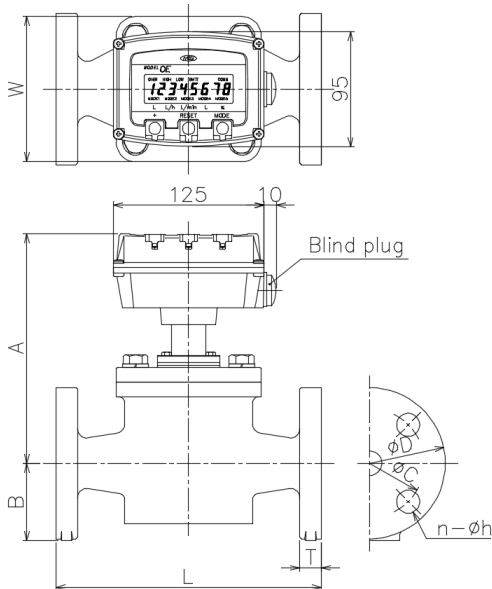

Pulse, & alarm output, and analog output type

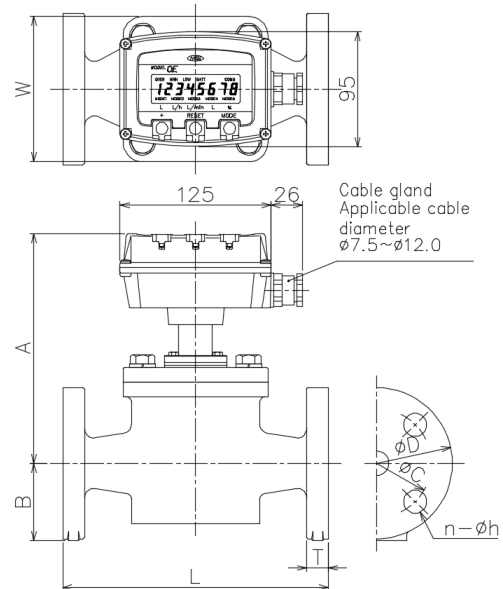

Nominal size & volume symbol	Nominal size	Flange standard	L	A	B	B1	W	D	T	C	n	h	Weight (kg)
015L0	15A	JIS10K	140	165	48	33	70	95	16	70	4	15	4.2
020S0	20A	JIS10K	160	172	51	33	78	100	18	75	4	15	5.0
020M0	20A	JIS10K	160	174	51	37	78	100	18	75	4	15	5.2
020L0	20A	JIS10K	160	170	51	41	78	100	18	75	4	15	5.0
025L0	25A	JIS10K	220	193	64	50	120	125	18	90	4	19	10.5
040L0	40A	JIS10K	245	225	70	79	155	140	20	105	4	19	18.0

Field indication type
(for high temperature specification)

Pulse, & alarm output, and analog output type
(for high temperature specification)

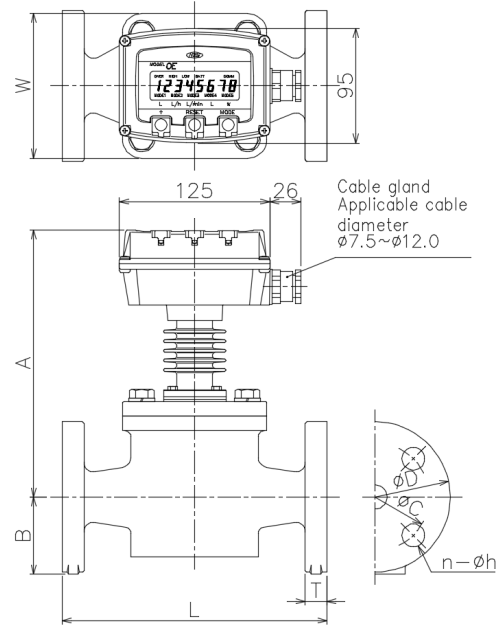
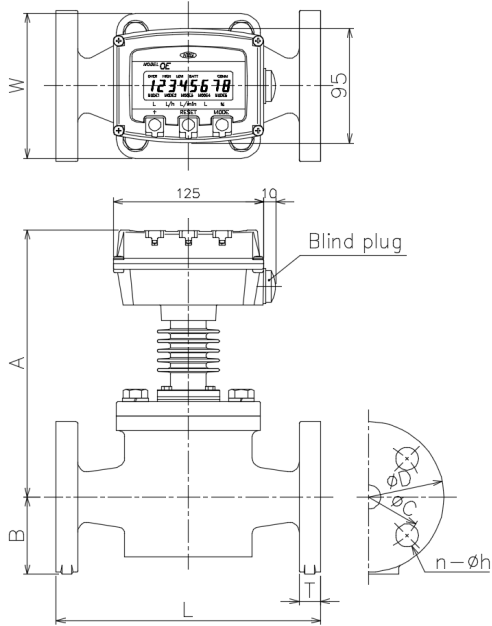

Nominal size & volume symbol	Nominal size	Flange standard	L	A	B	B1	W	D	T	C	n	h	Weight (kg)
015L0	15A	JIS10K	140	197	48	33	70	95	16	70	4	15	4.6
020S0	20A	JIS10K	160	204	51	33	78	100	18	75	4	15	5.4
020M0	20A	JIS10K	160	206	51	37	78	100	18	75	4	15	5.6
020L0	20A	JIS10K	160	202	51	41	78	100	18	75	4	15	5.4
025L0	25A	JIS10K	220	225	64	50	120	125	18	90	4	19	10.9
040L0	40A	JIS10K	245	257	70	79	155	140	20	105	4	19	18.4

Batch type

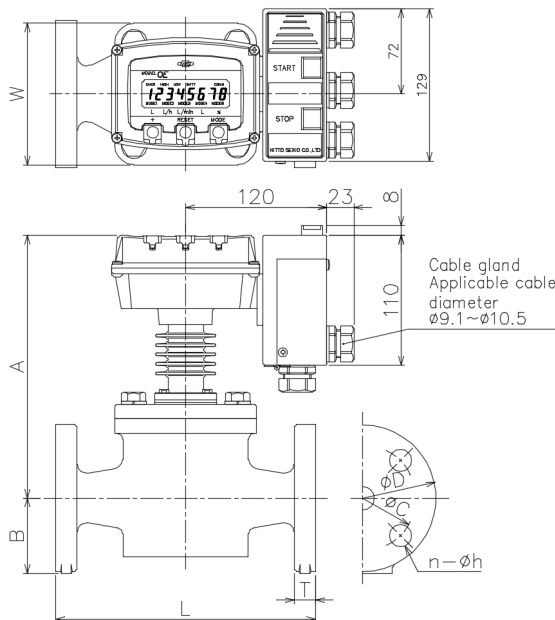

Nominal size & volume symbol	Nominal size	Flange standard	L	A	B	B1	W	D	T	C	n	h	Weight (kg)
015L0	15A	JIS10K	140	197	48	33	70	95	16	70	4	15	5.2
020S0	20A	JIS10K	160	204	51	33	78	100	18	75	4	15	6.0
020M0	20A	JIS10K	160	206	51	37	78	100	18	75	4	15	6.2
020L0	20A	JIS10K	160	202	51	41	78	100	18	75	4	15	6.0
025L0	25A	JIS10K	220	225	64	50	120	125	18	90	4	19	11.5
040L0	40A	JIS10K	245	257	70	79	155	140	20	105	4	19	19.0

8. Operation

8.1 Common operation

- **Flow rate**
Measure the time required for one turn of the rotor of the flow meter, calculates the flow rate and indicate the momentary flow rate.
- **Total value**
Integrally indicates the pulse signals from measuring unit in specified unit.
- **Alarm**
HIGH Indicated when flow exceed upper limit. ※2
LOW Indicated when flow is less than lower limit. ※2
BATT Indicated when battery capacity is low. Battery should be changed to new battery.
Activate only in case of flow meter with battery.
※2 : Limit of alarm is changed by data setting.

8.2. Field indication type

- **Operation**
It indicates flow rate, total value and alarm operating by battery. It does not output pulse, alarm or analog signal.

8.3. Pulse & alarm output type

- **Battery, external power supply**
 - Flow meter without battery type does not indicate flow rate, total value, or alarm without external power supply.
 - Flow meter with battery type indicate flow rate, total value, and alarm without external power supply. However, It cannot output pulse or alarm signal without external power supply. Battery power is not consumed while supply external power. It makes the battery life lengthen.
- **Button operation**
 - The mode change as shown in figure below with pressing of the [MODE] button.

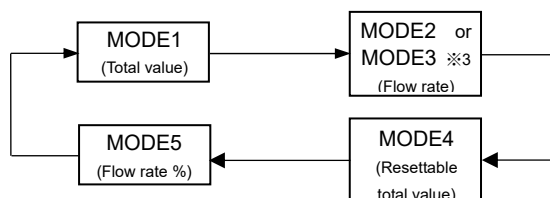

※3 : Depending on the setting, "MODE2 (/h)" or "MODE3 (/min)" is indicated.

- **Reset operation**
While indicating "MODE4" (Resettable total value), pressing [RESET] button makes total value reset to zero.
- **Pulse output ※4**
Unitless pulse output : Output pulse signal from measuring unit without any calculation.
Unit pulse output : Output specified unit of pulse signal.
- **Alarm output ※4**
Signal is output when reaching respective alarm point.
- **Simulation output**
Unit pulse or alarm output (except for battery alarm) is experimentally output.
※4 : Output signal can be changed by data setting.

8.4 Analog output type

- **Battery, external power supply**
 - Flow meter without battery type does not indicate flow rate, total value, or alarm without external power supply.
 - Flow meter with battery type indicate flow rate, total value, and alarm without external power supply.

However, It cannot output analog signal without external power supply.

Battery power is not consumed while supply external power. It makes the battery life lengthen.

- **Button operation**
Refer to article of Pulse & alarm output type
- **Reset operation**
Refer to article of Pulse & alarm output type
- **Analog signal output**
Output flow rate as 4-20mA DC
- **Simulation output**
Analog signal is experimentally output.

8.5 Batch type

- **External power supply**
Both signal output and batch operation are unavailable without external power supply.
- **Batch method**
Subtract method
- **Operation switch**
[START], [STOP], [RESET]
- **Setting of batch counter**
Digits shift [RESET], Number change [+], Entry [MODE]
- **Pulse output**
Refer to article of Pulse & alarm output type
- **Alarm output**
Refer to article of Pulse & alarm output type
- **Simulation output**
Refer to article of Pulse & alarm output type
- **Counting method**
 - No-count of excessive volume method
Counter starts counting by pressing [START] button and subtract batch counter. Measuring is stopped when batch counter become zero. Also [STOP] or [RESET] operation can stop measuring.
 - Count of excessive volume method
Counter starts counting by pressing [START] button and subtract batch counter, and [RESET] function can stop measuring. However, in case of flowing the liquid after even if batch counter become zero, or after even if operation of [STOP], it keeps measuring. In case of becoming zero, it will count up.
- **Reset method**
 - Automatic reset
Automatically reset when batch counter become zero.
 - Manual reset
Not reset though batch counter becomes zero. Reset by [RESET] button.
- **Button operation**
The mode change as shown in figure below with pressing of the [MODE] button.

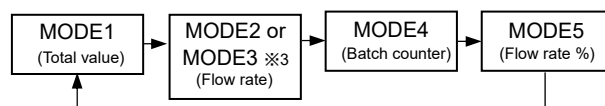

9. Terminal arrangement and wiring diagram

9.1 Terminal arrangement for pulse & alarm output

TB1

No.	Signal name
1	SIG1 Pulse output or alarm output
2	SIG2 Pulse output or alarm output
3	+12~24V
4	0V

TB2

No.	Signal name
1	Connect in case of batch type. Do not connect in case of other type.
2	
3	

9.2 Terminal arrangement for analog output

TB1

No.	Signal name
1	+ Analog output 4~20mA DC
2	

9.3 Terminal arrangement for batch type

TB3

No.	Signal name
1	Earth ground
2	(+) Power
3	(-) Power
4	(+) Metering signal 1
5	(-) Metering signal 1
6	Metering signal 2
7	
8	

TB4

No.	Signal name
1	SIG1 Pulse output or alarm output
2	SIG2 Pulse output or alarm output
3	0V

9.4 Wiring diagram for pulse & alarm output type

TB1

SIG1	SIG2	+12~24V	0V
1	2	3	4

TB2

1	2	3
---	---	---

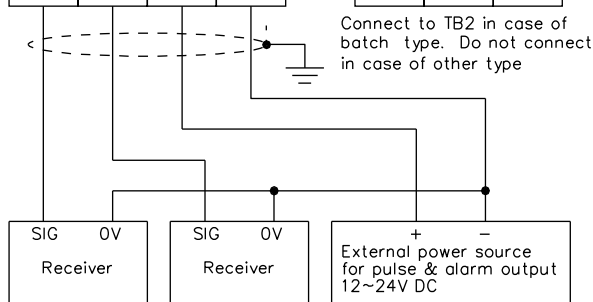

9.5 Wiring diagram for analog output type

TB1

+	-
1	2

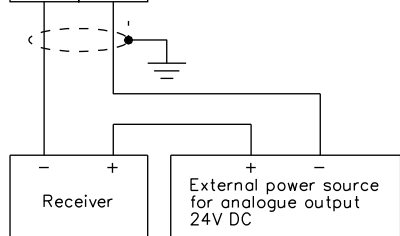

9.6 Wiring diagram for batch type

● AC type

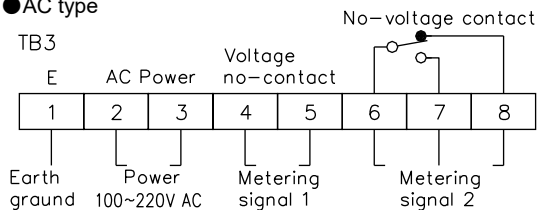

● 24V DC type

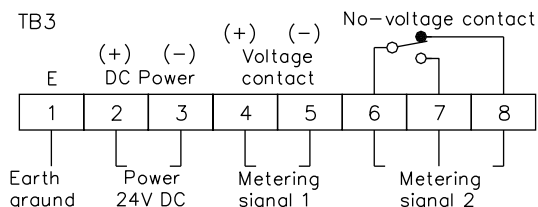

● Common of AC type and 24V DC type

TB4

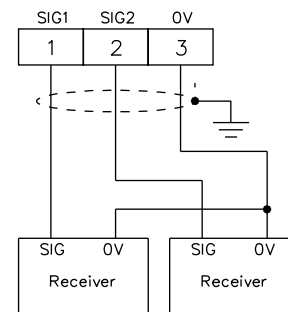

9.7 Circuit for pulse output and alarm output

Output signal Switch	Pulse & alarm output SIG1		Pulse & alarm output SIG2	
	DS1-1	DS1-2	DS1-5	DS1-6
Kind of output signal	DS1-1	DS1-2	DS1-5	DS1-6
Voltage no-contact	OFF	ON	OFF	ON
Open collector	ON	OFF	ON	OFF

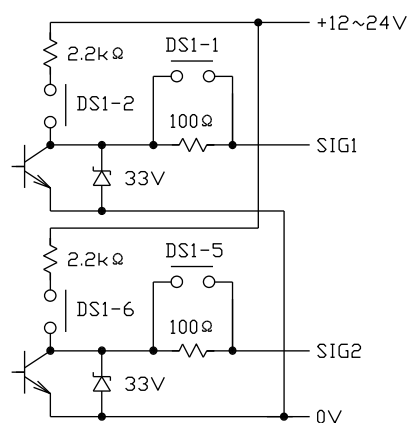

Output terminal No. Name	Pulse & alarm output TB1 Terminal No.	Batch type TB4 Terminal No.
SIG1	1	1
SIG2	2	2
+12~24V	3	-
0V	4	3

10. Product code and specification code

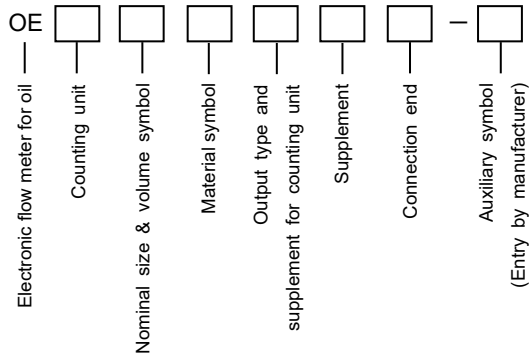

● : Standard; ○ : Manufacturable; × : Unavailable

Type	Specification code	Specification	015L0	020S	020M	020L	025L	040L
OE		Electronic flow meter for oil	●	●	●	●	●	●
Counting unit	3E	Electronic indication	●	●	●	●	●	●
Nominal size & volume symbol	015L0	Nominal size : 15A Max flow rate : 200L/h	●					
	020S0	Nominal size : 20A Max flow rate : 200L/h		●				
	020M0	Nominal size : 20A Max flow rate : 400L/h			●			
	020L0	Nominal size : 20A Max flow rate : 1000L/h				●		
	025L0	Nominal size : 25A Max flow rate : 2500L/h					●	
	040L0	Nominal size : 40A Max flow rate : 6000L/h						●
Material symbol	FB	Body : FC200, Main body cover : AC2A(015L0: A5052)	●	●	●	●	●	●
Output type and supplement for counting unit	12345	Field indication type (without output type)	Non-explosion proof	With battery	●	●	●	●
	P0345	Pulse/alarm output ※5	Non-explosion proof	No battery	●	●	●	●
	P00B0		Non-explosion proof	With battery	○	○	○	○
	A0345	Analog output	Non-explosion proof	No battery	●	●	●	●
	A00B0		Non-explosion proof	With battery		○		○
	PB345	Batch: AC ※5	Non-explosion proof	No battery	●	●	●	●
	PC345	Batch: 24V DC ※5	Non-explosion proof	No battery	●	●	●	●
Supplement	0	Max. temperature 80°C		●	●	●	●	●
	1	Max temperature 120°C (High temp. type) or In case of batch type		○	○	○	○	○
Connection end	010F	JIS10K FF Flange		●	●	●	●	●

※5 : SIG1 and SIG2 output of standard article are delivered with the following setting.

- SIG1 output : Kind of signal Voltage no-contact
- Electronic logic Positive logic
- Pulse output Unitless pulse output
- SIG2 output : Kind of signal Voltage no-contact
- Electronic logic Positive logic
- Pulse output Unit pulse output

11. Strainer

To prevent foreign matters mixed in the liquid from penetrating into the flow meter to cause trouble, it is necessary to install a strainer immediately before the flow meter or at a point as close as possible to the inflow side. (STD 60 mesh)

◆◆◆◆◆◆ Matters to be specified at the time of ordering ◆◆◆◆◆◆

1. Type and specification code.
2. Name of measured liquid, viscosity, temperature.
3. Flow direction of fluid, mounting position.

▼ The contents given here are subject to change without notice.

NITTOSEIKO CO.,LTD.



Control System Division Global Sales Section [Website] [Inquiry Form]
 Website: <https://global.nittoseiko.com/>