

## FIELD COUNTER TYPE PNEUMATIC BATCH

## SPECIFICATIONS

SSV11252 25.07

## 1. Outline

The field counter type pneumatic batch counter RSCN, comprising a mechanical preset counter and a totalizing counter, can make metering batch easily in the field, by combination with a pneumatic valve. The set volume can be selected as desired with a set button. If you press the start switch, the valve opens to start measuring and, when the set volume is reached, the valve automatically closes. This flow meter works only with pneumatic signals, and can be used safely even in a hazardous area requiring explosion proof construction.

## 2. Features

- Using air source as operation power without power of any kind.
- Applicable without fear to the place where explosion proof is necessary.
- Desired volume is set at field.
- Easy operation as push button setting type.
- Low air consumption and economical.
- Easy expansion with variety of pulse generators available for loading.

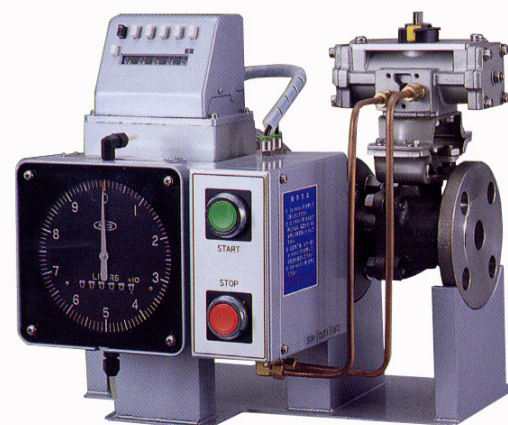

## 3. Specifications

## Specifications of measuring unit

Nominal size & volume symbol	025		040		050		080		100
	A0	B0	A0	B0	A0	B0	A0	B0	A0
Measured liquid	Chemical solutions, edible liquids, petroleum, water, etc.								
Nominal size	25A		40A		50A		80A		100A
Liquid viscosity	0.5~3,000 mPa·s (Special application 0.2~30,000 mPa·s)								
Liquid temperature	Normal temperature~80°C (Special application -20~150°C)								
Liquid pressure	1.0 MPa or less (Special application 2.0 MPa or less)								
Standard connection	JIS10K, 20K, ANSI class 150, 300 (For the details, see paragraph of "Process connection and face-to-face dimensions" )								
Material	Material symbol		Main body		Measuring chamber		Rotor		
	FB		FC200		CAC406		PPS, GC, AC		
	FF		FC200		FC200		PPS, GC, AC		
	F2		FC200		SCS14A		PPS, GC, AC		
	DB		FCD450		CAC406		PPS, GC, AC		
	DD		FCD450		FCD450		PPS, GC, AC		
	D2		FCD450		SCS14A		PPS, GC, AC		
S2		SCS14A		SCS14A		PPS, GC, AC			
Special specifications	FC200:Cast iron, FCD450:Ductile cast iron, CAC406:Cast bronze, SCS14A: Stainless steel casting, PPS: Special plastic, GC: Carbon, AC: Corrosion-resistant aluminum Article approved for high-pressure gas service: Only material symbol S2 is manufacturable. (Up to nominal size 80A)								

## Specification of counter unit

Item	Model	
	Single-stage type	Two-stage type
Totalizing unit	Totalizing counter	6 digits
	Indication unit	L (Standard)
Setting counter unit and control equipment unit	Control system	Single-stage open and close by air   Single-stage open and two-stage close by air
	Air pressure of signal	0.3~0.6 MPa (According to the connected valve specification)
	Air pipe connecting size	Rc1/4 (Both of supply and output port)
	Predictive signal setting value	Before 10 or 100L from set value
	Start/stop	Manual push-button
	Setting system	5 digits push-button
	Reset system	Manual push-button reset
	Setting drum	5digits subtraction type setting drum with addition drum   5 digits subtraction type setting drum
Repeat function	With	
Allowable ambient temperature	0~60°C (Liquid temperature 80°C or under)	
Mounting posture	Horizontal	

Counting units

Single-stage type counter unit

Unit:L

Nominal size & volume symbol	Totalizing counter unit				Setting counter unit	
	Pointer per rev.	Min. scale unit	Totalizing counter ( 6 digits)		Min. setting unit, volume in ( ) is special.	Max. setting volume
			Max. totalizing volume	Totalizing unit		
0 2 5 A 0	1 0	0. 1	9, 999, 990	1 0	1 (10)	99, 999
0 2 5 B 0	1 0	0. 1	9, 999, 990	1 0	1 (10)	99, 999
0 4 0 A 0	1 0	0. 1	9, 999, 990	1 0	1 (10)	99, 999
0 4 0 B 0	1 0	0. 1	9, 999, 990	1 0	1 (10)	99, 999
0 5 0 A 0	1 0	0. 1	9, 999, 990	1 0	1 (10)	99, 999
0 5 0 B 0	1 0 0	1	99, 999, 900	1 0 0	1 0 (100)	999, 990
0 8 0 A 0	1 0 0	1	99, 999, 900	1 0 0	1 0 (100)	999, 990
0 8 0 B 0	1 0 0	1	99, 999, 900	1 0 0	1 0 (100)	999, 990
1 0 0 A 0	1 0 0	1	99, 999, 900	1 0 0	1 0 (100)	999, 990

Note 1. Min. setting unit shown in ( ) are available. On this case, setting volume and volume of pointer per rev. are changed with same ratio.

2. To assure the accuracy, set a setting value more than 50 times of min. setting unit.

Two-stage type counter unit

Unit:L

Nominal size & volume symbol	Totalizing counter unit				Setting counter unit		
	Pointer per rev.	Min. scale unit	Totalizing counter ( 6 digits)		Min. setting unit, volume in ( ) is special.	Max. setting volume	Predictive signal setting value
			Max. totalizing volume	Totalizing unit			
0 2 5 A 0	1 0	0. 1	9, 999, 990	1 0	1 (10)	99, 999	1 0
0 2 5 B 0	1 0	0. 1	9, 999, 990	1 0	1 (10)	99, 999	1 0
0 4 0 A 0	1 0	0. 1	9, 999, 990	1 0	1 (10)	99, 999	1 0
0 4 0 B 0	1 0	0. 1	9, 999, 990	1 0	1 (10)	99, 999	1 0
0 5 0 A 0	1 0	0. 1	9, 999, 990	1 0	1 (10)	99, 999	1 0
0 5 0 B 0	1 0 0	1	99, 999, 900	1 0 0	1 0 (100)	999, 990	1 0 0
0 8 0 A 0	1 0 0	1	99, 999, 900	1 0 0	1 0 (100)	999, 990	1 0 0
0 8 0 B 0	1 0 0	1	99, 999, 900	1 0 0	1 0 (100)	999, 990	1 0 0
1 0 0 A 0	1 0 0	1	99, 999, 900	1 0 0	1 0 (100)	999, 990	1 0 0

Note 1. Min. setting unit shown in ( ) are available. On this case, setting volume and volume of pointer per rev. are changed with same ratio.

2. To assure the accuracy, set a setting value more than 50 times of min. setting unit.

3. Do not set the setting value less than predictive signal setting value, as valve will not open.

Output pulse unit table (Optional)

No-contact output pulse unit table ( ●: Photoelectric type, ○: High frequency type, ◎: High frequency/Photoelectric type )

Nominal size & volume symbol	Pointer per rev.	Pulse unit						
		1mL/P	10mL/P	100mL/P	1L/P	10L/P	100L/P	1m <sup>3</sup> /p
0 2 5 A 0	10L	●	◎	○	○	—	—	—
0 2 5 B 0	10L	●	◎	○	○	—	—	—
0 4 0 A 0	10L	●	◎	○	○	—	—	—
0 4 0 B 0	10L	●	◎	○	○	—	—	—
0 5 0 A 0	10L	●	◎	○	○	—	—	—
0 5 0 B 0	100L	—	●	◎	○	○	—	—
0 8 0 A 0	100L	—	●	◎	○	○	—	—
0 8 0 B 0	100L	—	●	◎	○	○	—	—
1 0 0 A 0	100L	—	●	◎	○	○	—	—

Contact output pulse table (○: Reed switch)

Nominal size & volume symbol	Pointer per rev.	Pulse unit						
		1mL/P	10mL/P	100mL/P	1L/P	10L/P	100L/P	1m <sup>3</sup> /p
0 2 5 A 0	10L	—	—	○	○	○	—	—
0 2 5 B 0	10L	—	—	○	○	○	—	—
0 4 0 A 0	10L	—	—	○	○	○	—	—
0 4 0 B 0	10L	—	—	○	○	○	—	—
0 5 0 A 0	10L	—	—	○	○	○	—	—
0 5 0 B 0	100L	—	—	—	○	○	○	—
0 8 0 A 0	100L	—	—	—	○	○	○	—
0 8 0 B 0	100L	—	—	—	○	○	○	—
1 0 0 A 0	100L	—	—	—	○	○	○	—

4. Flow range (m<sup>3</sup>/h)

Accuracy: ±0.5%

Nominal size & volume symbol	Working condition	Water (normal temperature)	Hot water (60~120°C)	0.5mPa·s~	1mPa·s~	4mPa·s~	10mPa·s~	50~500mPa·s
O 2 5 A O	Intermittent	0.3~1.6	0.3~1.6	0.3~1.6	0.3~1.6	0.13~1.6	0.1~1.6	0.04~1.6
O 2 5 B O	Intermittent	0.5~3.5	0.65~2.5	0.65~4.0	0.5~5.0	0.35~5.0	0.2~5.0	0.17~5.0
O 4 0 A O	Intermittent	0.5~3.5	0.65~2.5	0.65~4.0	0.5~5.0	0.35~5.0	0.2~5.0	0.17~5.0
O 4 0 B O	Intermittent	1.2~8.5	1.5~6.0	1.5~10	1.2~12	0.65~12	0.5~12	0.36~12
O 5 0 A O	Intermittent	1.2~8.5	1.5~6.0	1.5~10	1.2~12	0.65~12	0.5~12	0.36~12
O 5 0 B O	Intermittent	2.4~17	3.0~12	3.0~20	2.4~24	1.2~24	1.0~24	0.75~24
O 8 0 A O	Intermittent	2.4~17	3.0~12	3.0~20	2.4~24	1.2~24	1.0~24	0.75~24
O 8 0 B O	Intermittent	5.0~35	6.0~25	6.0~40	5.0~50	2.5~50	2.0~50	1.5~50
1 0 0 A O	Intermittent	5.0~35	6.0~25	6.0~40	5.0~50	2.5~50	2.0~50	1.5~50

5. Pressure loss

Nominal size & volume symbol : O25A0

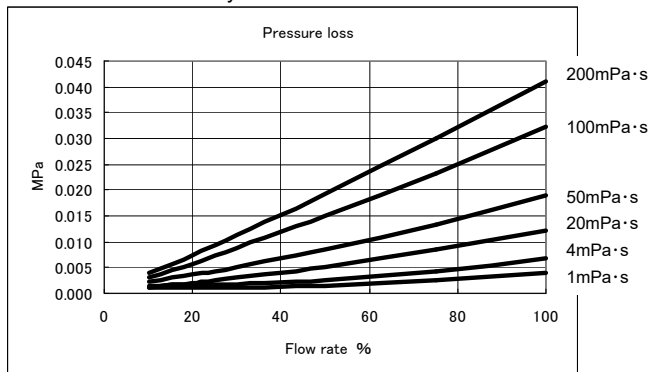

100% Flow rate

Nominal size & volume symbol	100% Flow rate
O 2 5 A O	1.6 m <sup>3</sup> /h

Nominal size & volume symbol : O25B0~100A0

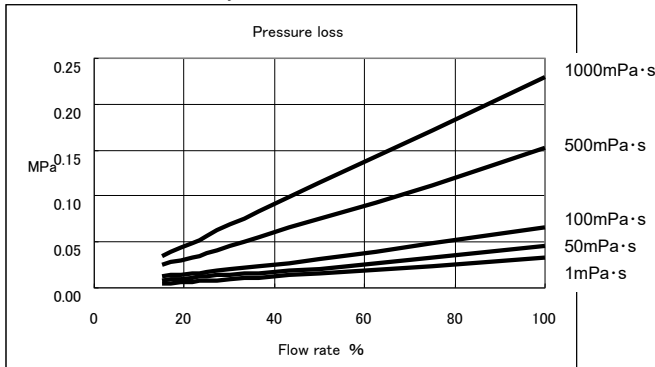

100% Flow rate

Nominal size & volume symbol	100% flow rate
O 2 5 B O	5.0 m <sup>3</sup> /h
O 4 0 A O	5.0 m <sup>3</sup> /h
O 4 0 B O	12.0 m <sup>3</sup> /h
O 5 0 A O	12.0 m <sup>3</sup> /h
O 5 0 B O	24.0 m <sup>3</sup> /h
O 8 0 A O	24.0 m <sup>3</sup> /h
O 8 0 B O	50.0 m <sup>3</sup> /h
1 0 0 A O	50.0 m <sup>3</sup> /h

6. Process connection and face-to-face dimensions (mm)

Nominal size & volume symbol	Material symbol	JIS		ANSI, JPI	
		10K	20K	Class150	Class 300
O25A0	FB/FF/F2	200	—	200	—
	DD/D2	200	204	200	208
	S2	200	204	200	208
O25B0	FB/FF/F2	220	—	221	—
	DB/DD/D2	220	224	221	228
	S2	220	224	221	228
O40A0 O40B0	FB/FF/F2	300	—	304	—
	DB/DD/D2	300	304	304	310
	S2	300	304	304	310
O50A0 O50B0	FB/FF/F2	370	—	378	—
	DB/DD/D2	370	374	378	384
	S2	370	374	378	384
O80A0 O80B0	FB/FF/F2	400	—	412	—
	DB/DD/D2	400	408	412	422
	S2	400	408	412	422
100A0	FB/FF/F2	460	—	472	—
	DB/DD/D2	460	472	472	488
	S2	460	472	472	488

Note: Process connections for which no numerical value is indicated on the table can not be manufactured.

7. Air signal time chart

● Single-stage type

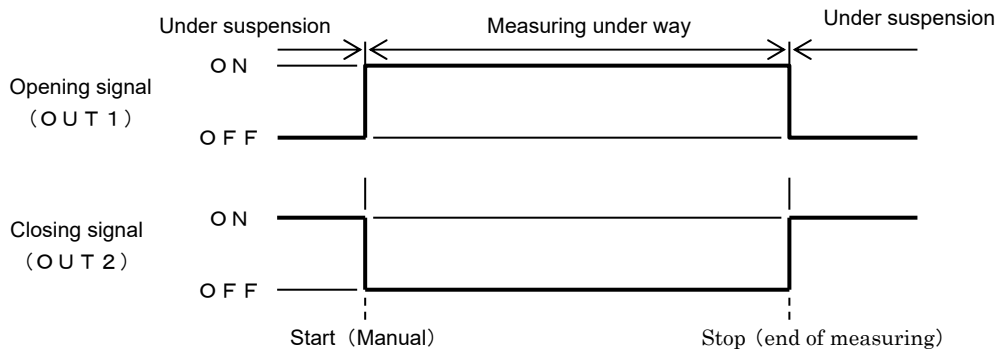

● Two-stage type

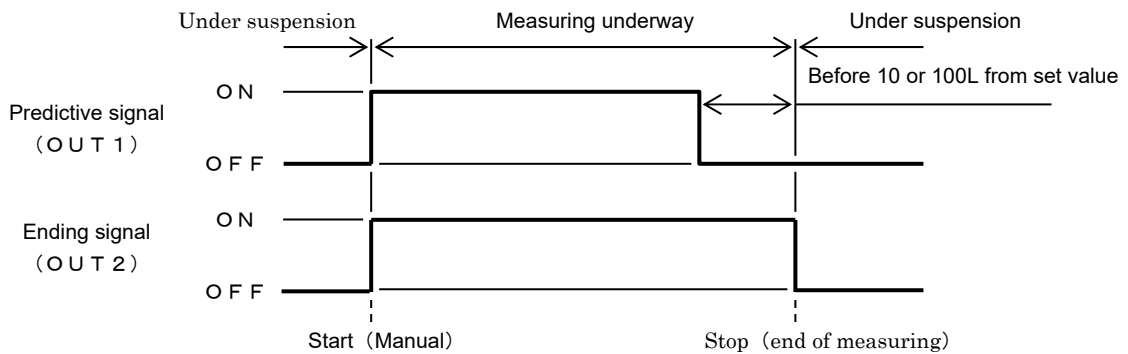

8. Standard connection diagram

● Example of single-stage setting type connection diagram

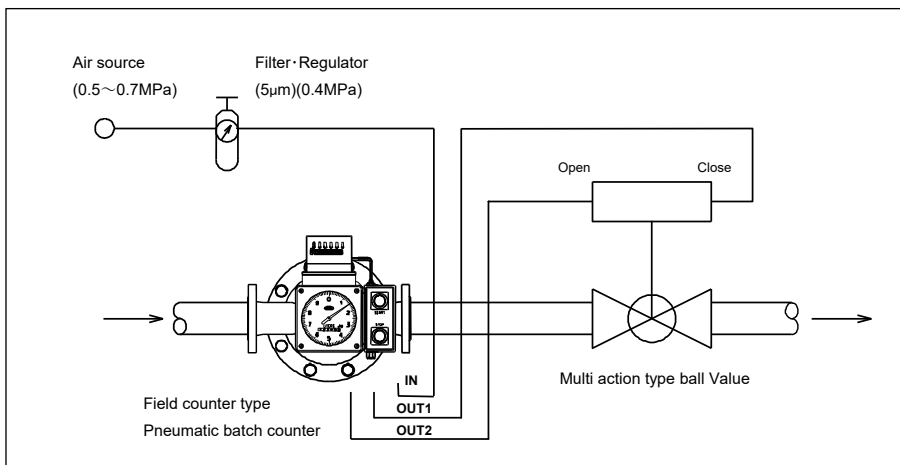

● Example of two-stage setting type connection diagram

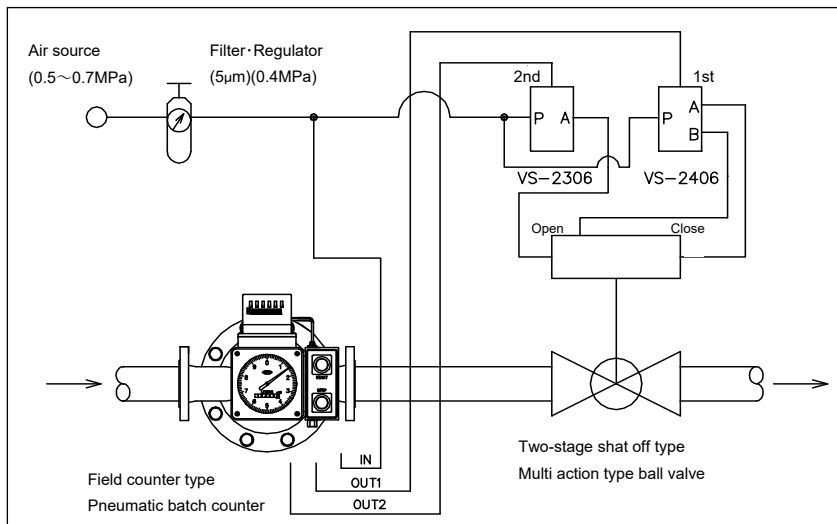

- (1) Spring return type ball valve (Single acting type) and two-stage shut-off ball valve can be connected.
- (2) By using pressure switch, interlocking operation with pump is possible.

9. External dimensions (mm)

● Single-stage type

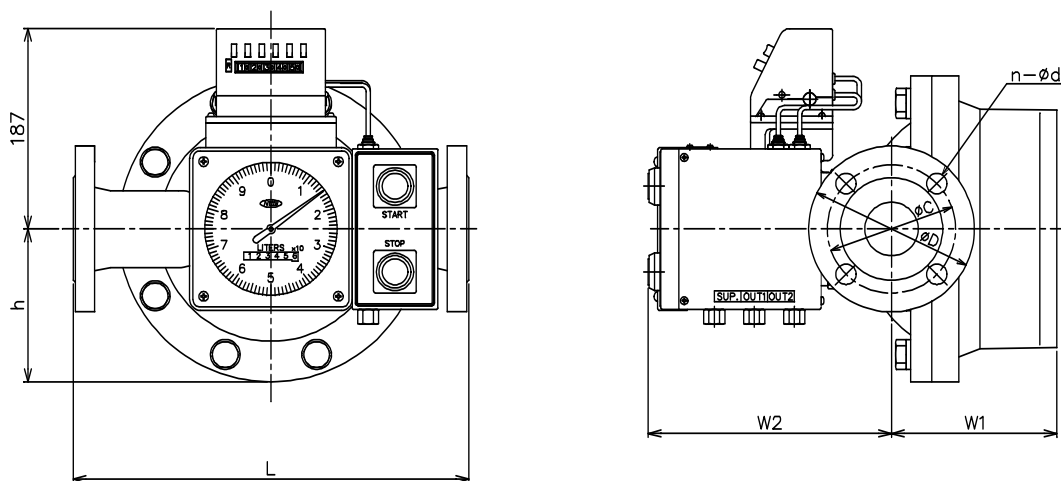

● Two-stage type

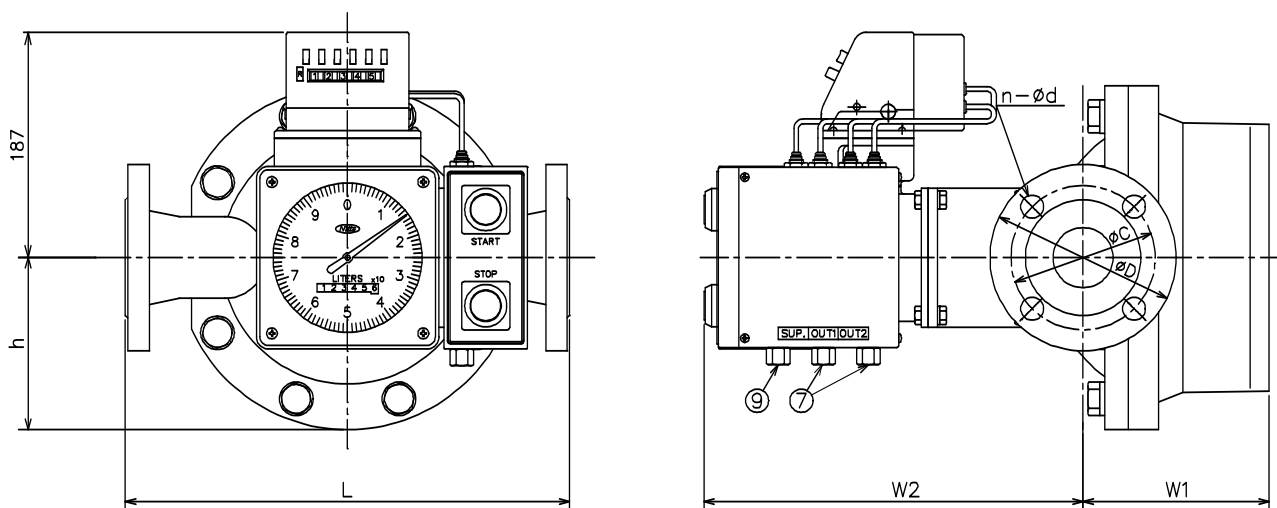

Nominal size & volume symbol	Flange standard	L	h	W 1	W 2 (Single-stage)	W 2 (Two-stage)	D	C	n	d	Weight (kg)
025A0	JIS10K	200	90	90	351	351	125	90	4	19	16.5
	JIS20K	204					125	90			
025B0	JIS10K	220	85	96	238	327	125	90	4	19	19.5
	JIS20K	224					125	90			
040A0	JIS10K	300	85	96	238	327	140	105	4	19	21.5
	JIS20K	304					140	105			
040B0	JIS10K	300	110	123	249	337	140	105	4	19	30.5
	JIS20K	304					140	105			
050A0	JIS10K	370	110	123	249	337	155	120	4	19	33.5
	JIS20K	374					155	120			
050B0	JIS10K	370	143	156	235	323	155	120	4	19	50.5
	JIS20K	374					155	120			
080A0	JIS10K	400	143	156	235	323	185	150	8	19	53.5
	JIS20K	408					200	160			
080B0	JIS10K	400	170	222	243	332	185	150	8	19	83.5
	JIS20K	408					200	160			
100A0	JIS10K	460	170	222	243	332	210	175	8	19	88.5
	JIS20K	472					225	185			

Note) 1. Dimension W2 is differed in single-stage setting type and two-stage setting type. However, nominal size & volume symbol 025A0 is same in both type.

2. Weight (kg) is showing approx. weight of single-stage setting type. As for the two-stage setting type, please add 1 kg to this value.

10. Product code

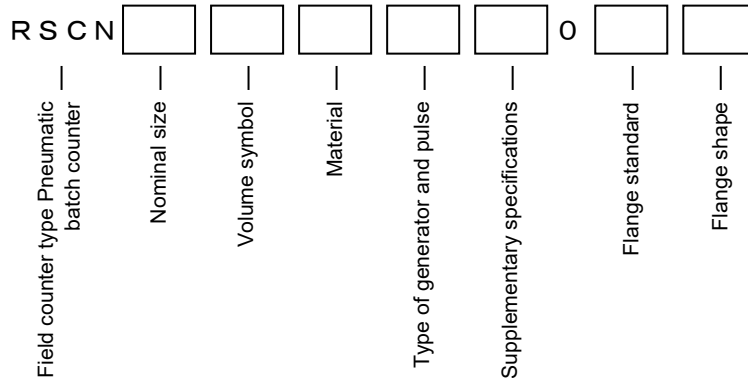

● : Standard; ○ : Manufacturable; × : Non-manufacturable

Type	Specification code		Specifications	025		040		050		080		100
				A0	B0	A0	B0	A0	B0	A0	B0	A0
RS			Rotary flow meter	●	●	●	●	●	●	●	●	●
Counter symbol	CN		Field counter type pneumatic batch counter	●	●	●	●	●	●	●	●	●
Nominal size symbol	025		Nominal size: 25A	●	●							
		040	Nominal size: 40A			●	●					
		050	Nominal size: 50A					●	●			
		080	Nominal size: 80A							●	●	
		100	Nominal size: 100A									●
Volume symbol	A0		Volume small	●		●		●		●		●
	B0		Volume large		●		●		●		●	
Material symbol	FB		Main body: FC200, Measuring chamber: CAC406, Rotor: PPS, GC, AC	●	●	●	●	●	●	●	●	●
	FF		Main body: FC200, Measuring chamber: FC200, Rotor: PPS, GC, AC	○	○	○	○	○	○	○	○	○
	F2		Main body: FC200, Measuring chamber: SCS14A, Rotor: PPS, GC, AC	○	○	○	○	○	○	○	○	○
	DB		Main body: FCD450, Measuring chamber: CAC406, Rotor: PPS, GC, AC	○	○	○	○	○	○	○	○	○
	DD		Main body: FCD450, Measuring chamber: FCD450, Rotor: PPS, GC, AC	○	○	○	○	○	○	○	○	○
	D2		Main body: FCD450, Measuring chamber: SCS14A, Rotor: PPS, GC, AC	○	○	○	○	○	○	○	○	○
	S2		Main body: SCS14A, Measuring chamber: SCS14A, Rotor: PPS, GC, AC	○	○	○	○	○	○	○	○	○
			FC200: Cast iron, FCD450: Ductile cast iron, CAC406: Cast bronze, SCS14A: Stainless steel casting; PPS: Special plastic; GC: Carbon; AC: Corrosion-resistant aluminum									
Type of generator and pulse unit	Note) The pulse units available for output are restricted depending on: (1) pointer specifications, and (2) type of generator. Refer to "Output Pulse Unit Table".	12	Without pulse output	●	●	●	●	●	●	●	●	●
		R3	Reed switch (contact) pulse 1L/p	○	×	×	×	×	×	×	×	×
		R4	Reed switch (contact) pulse 10L/p	○	○	○	○	○	×	×	×	×
		R5	Reed switch (contact) pulse 100L/p	×	×	×	×	×	○	○	○	○
		M2	High frequency (no-contact) pulse 0.01L/p	○	○	○	×	×	×	×	×	×
		M3	High frequency (no-contact) pulse 0.1L/p	○	○	○	○	○	×	×	×	×
		M4	High frequency (no-contact) pulse 1L/p	○	○	○	○	○	○	○	○	○
		M5	High frequency (no-contact) pulse 10L/p	×	×	×	(○)	(○)	○	○	○	○
		MD	High frequency (no-contact) pulse DA conversion pulse	○	○	○	○	○	○	○	○	○
		K1	Photoelectric (no-contact) pulse 0.001L/p	○	○	○	×	×	×	×	×	×
K2	Photoelectric (no-contact) pulse 0.01L/p	×	×	×	○	○	×	×	×	×		
K3	Photoelectric (no-contact) pulse 0.1L/p	×	×	×	×	×	○	○	○	○		
Supplementary specifications	345		Non-explosion proof & without radiating fins	●	●	●	●	●	●	●	●	●
	X00		Flameproof enclosure type	○	○	○	○	○	○	○	○	○
	X01		Flameproof enclosure type + Single-stage radiating fin	○	○	○	○	○	○	○	○	○
	001		Single-stage radiating fin	○	○	○	○	○	○	○	○	○
	00J		With jacket	○	○	○	○	○	○	○	○	○
	00W		With jacket + radiating fin	○	○	○	○	○	○	○	○	○
			Single-stage fin in the case where the liquid temperature exceeds 80°C.									
Flange standard	005		JIS 5K	○	○	○	○	○	○	○	○	○
	010		JIS 10K	●	●	●	●	●	●	●	●	●
	020		JIS 20K	○	○	○	○	○	○	○	○	
	AS1		ANSI class 150	○	○	○	○	○	○	○	○	
	AS3		ANSI class 300	○	○	○	○	○	○	○	○	
Flange shape	F		FF flange	○	●	○	○	○	○	○	○	○
	R		RF flange	●	○	●	●	●	●	●	●	●

Note) No explosion proof type is available in the photoelectric pulse generator type.

▼The contents given here are subject to change without notice.

**NITTOSEIKO CO.,LTD.**



Control System Division Global Sales Section [Website] [Inquiry Form]

Website: <https://global.nittoseiko.com/>