

Flow meter for high pressure

SPECIFICATIONS

SSV12352 25.07

1. Outline

This is direct-pulse output type flow meter for high pressure and its gearless structure is improved from existing flow meter for high pressure.

This flow meter which is small-size and simple-structure is suitable for hydraulic line, control and management of paint line and so on.

2. Features

- Structure without coupling-magnet and gears was realized by the direct transmitting of the rotor rotation as a pulse signal.
- This is small-size and light-weight flow meter which is unified measuring chamber and main body.
- It resists up to 21MPa of operation pressure.

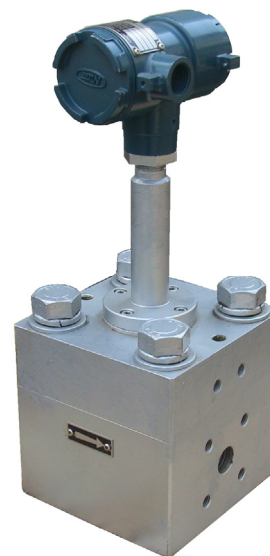

3. Specifications

Specification of measuring unit

Nominal size and volume symbol	20C	25C	25E	40F
Measured fluid	Kind of oil such as hydraulic oil, paint etc.			
Nominal size	20A	25A		40A
Liquid viscosity	2~5,000mPa·s (Manufacturable more than 5,000mPa·s)			
Liquid temperature	-5~120°C			
Liquid pressure	21.0MPa or less			
Arrow able pressure	21.0MPa (120°C or less of liquid)			
Measuring accuracy	Within ±0.5%			
Standard connection	JIS B 2291 Equivalent of 21MPa pipe flange for hydraulic oil			
Material	Main body : S45C, Measuring chamber cover : SUS304, Rotor : AC3A			Main body : S25C, Rotor : AC3A
	Upper cover and measuring chamber cover : SUS304			
S45C,S25C ; SC steel, SUS304 ; Stainless steel casting, AC3A ; Aluminum alloy				

Specification of counting unit

Nominal size and volume symbol	20C	25C	25E	40F		
Indication	Without					
Output	Pulse output	No. of output	1 point			
		Output assignment	Unitless pulse			
		Kind of signal	Voltage no-contact or Open drain output Voltage no-contact ; Signal level H:Approx. external power voltage (at no load) L:0.5V or less Output resistance Approx. 2.3kΩ (Short-circuit protection resistance Approx.100Ω)		Open drain ; Voltage/Current 27V DC 30mA At ON Voltage 0.5V or less	
		Signal logic	Positive logic or negative logic Positive : At H(Transista : OFF), Logic 1, Negative : At L(Transista : ON), Logic 1			
		Unit pulse	Without			
		Unitless pulse	Unit※1	4.9mL	9.2mL	35.1mL
			Width	Approx. 3.5ms		
Analogue output	Without					
Power	External power : 12V~24V DC ±10%					
Current consumption	DC12V	Approx. 12mA		Approx. 20mA		
	DC24V	Approx. 18mA		Approx. 25mA		
Ambient temperature	0~60°C					
Explosion-	Non-explosion proof structure					
Water-proof	JIS C 0920 Water proof					
Material	Aluminum diecasting					

※1 Output pulse unit of unitless pulse means nominal value of pulse from intended flow meter.

4. Flow range (Unit : L/h)

Nominal size and volume symbol	2~10mPa·s	10~500mPa·s	500~1,000mPa·s	1,000~5,000mPa·s
20C	60 ~ 500	25 ~ 500	15 ~ 400	15 ~ 300
25C	140 ~ 1,000	80 ~ 1,000	20 ~ 800	20 ~ 600
25E	250 ~ 3,200	150 ~ 3,200	30 ~ 2,400	30 ~ 1,800
40F	300 ~ 6,000	170 ~ 6,000	40 ~ 4,800	40 ~ 3,600

Note: Please select flow meter size of which 40-60% of max flow rate is normal operating flow rate.

5. Pressure loss

Nominal size and volume symbol : 20C~40F

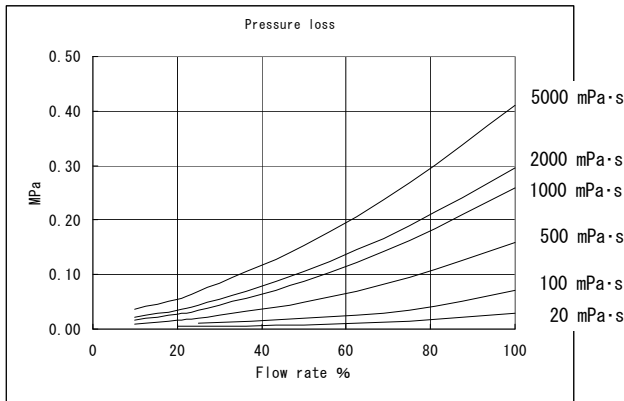

Nominal size Volume symbol	100% Flow		
	500mPa·s	1,000mPa·s	5,000mPa·s
20C	500L/h	400L/h	300L/h
25C	1,000L/h	800L/h	600L/h
25E	3,200L/h	2,400L/h	1,800L/h
40F	6,000L/h	4,800L/h	3,600L/h

6. Remote measurement system

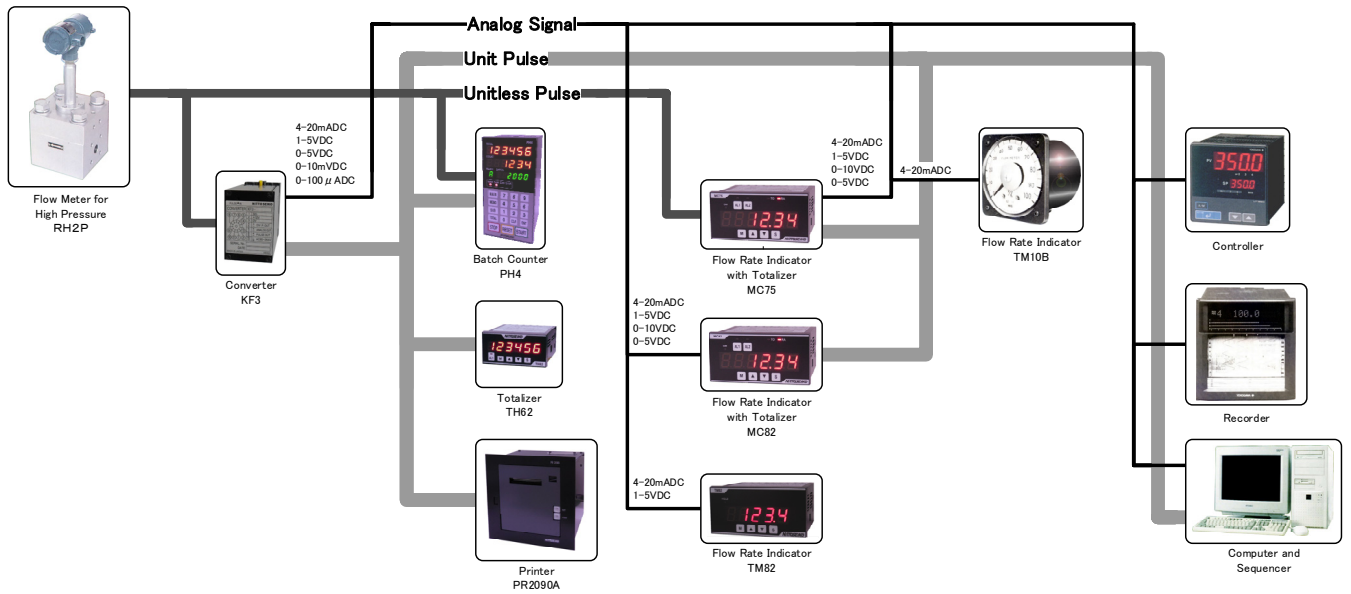

※The detailed input/output conditions vary depending on the specifications of the respective converter and receivers. Check with the specification sheet of the respective instruments.

7. External dimension (Unit : mm)

● Nominal size and volume symbol 20C,25C,25E

● Nominal size and volume symbol 40F

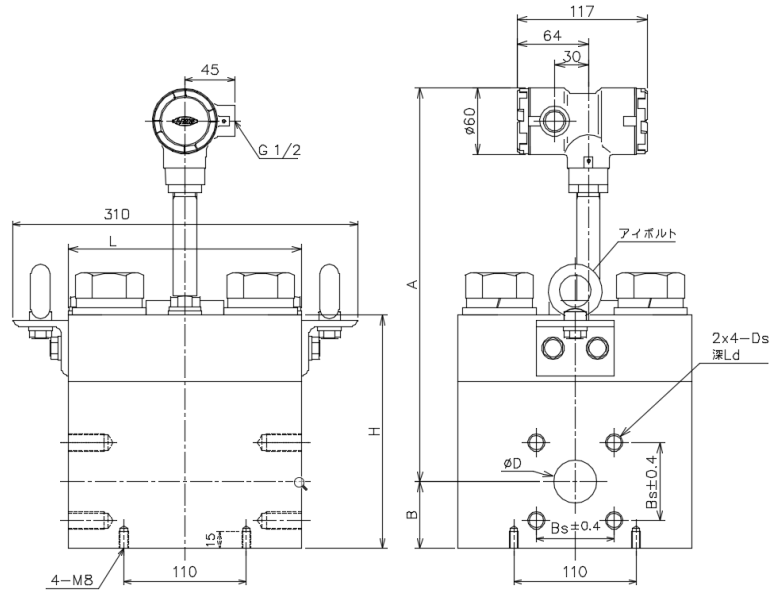
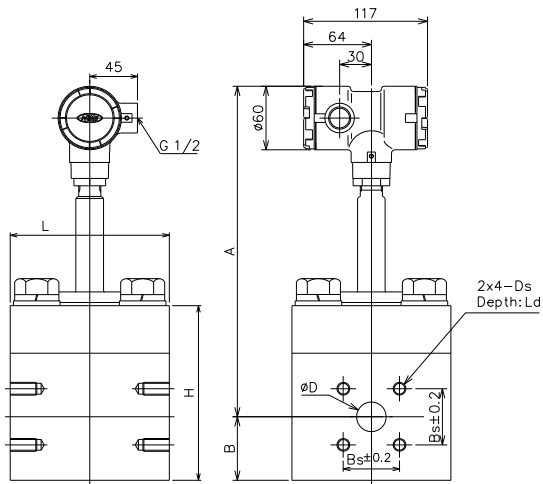

Nominal size & volume symbol	L	A	B	H	D	Bs	Ds	Ld	Weight (kg)
20C	135	298.5	45	136.5	20	45	M10	22	20
25C	135	298.5	45	136.5	25	53	M12	24	20
25E	150	312	60	165	25	53	M12	24	30
40F	210	354	60	210	40	70	M16	32	72

8. Terminal arrangement and wiring connection

8.1 Terminal arrangement

No.	Signal name
1	S I G Pulse output
2	+ 1 2 ~ 2 4 V
3	0 V

8.2 Wiring

● In case of using power for pulser of receiver

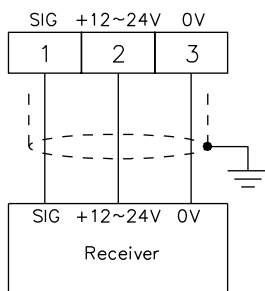

● In case of not using power for pulser of receiver

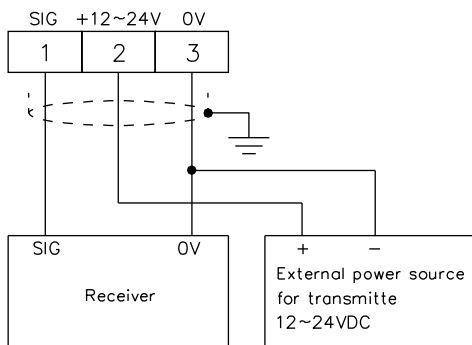

8.3 Pulse output circuit

Kind of signal	Switch	
	DS1-2	DS1-3
Voltage no-contact	ON	OFF
Open drain	OFF	ON

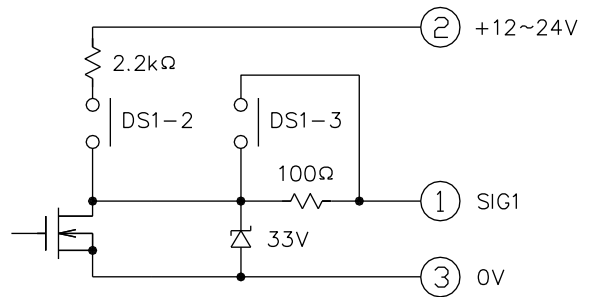

Note : Standard setting of pulse output is as below

Signal Voltage no-contact
Logic Positive

9. Model and specification code

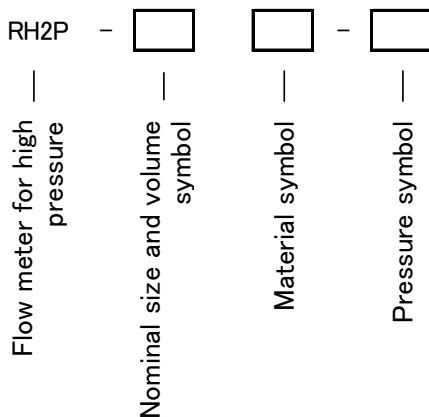

Model	Specification code		Specification
RH2P			Flow meter for high pressure
Nominal size and volume symbol	20C		Nominal size : 20A
	25C		Nominal size : 25A
	25E		Nominal size : 25A
	40F		Nominal size : 40A
Material symbol	SC		Body material : S45C or S25C
Pressure symbol		210	Press. : 21.0MPa or less

◆◆◆◆Please specify following article when order◆◆◆◆

1. Model and specification code
2. Measured liquid name, viscosity, temperature
3. Mounting position and flow direction

▼The contents given here are subject to change without notice.

NITTOSEIKO CO.,LTD.



Control System Division Global Sales Section . [Website] [Inquiry Form]
 Website: <https://global.nittoseiko.com/>