

## MICRO FLOW METER

## Nico Flow

## SPECIFICATIONS

SSV14752 23.11

## 1. Outline

Nico Flow is a rotary piston type flow meter for measuring small flow rate, having the simplest construction among positive displacement flow meters. This instrument can be utilized for a variety of controls and management such as process control of additives, control of mixing flow rate in chemical industry, management of small flow rate measurement such as measurement of dispensing water, etc.

## 2. Features

- Simple construction having only rotor as moving unit.
- Measuring accuracy within  $\pm 0.75\%$ .
- Compact size & light weight.
- Explosion proof construction: Flameproof enclosure type (Exd II BT4X)

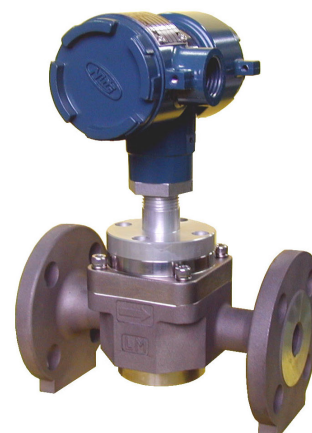

## 3. Specification

## Measuring unit

Volume symbol		10M0	10L0	10LM	10LL	10LG	20P0	
Measured liquid		Chemical solutions, food liquids, petroleum, water, etc.						
Nominal size	Material : LS,S2	1/4B,15A		1/2B,15A		1/2B,20A	-	
	Material : VV	1/2B,15A				3/4B,20A		
Liquid viscosity	Material : LS,S2	0.4~100mPa·s (Liquid viscosity more than 100mPa·s is available.)						
	Material : VV	0.8~100mPa·s						
Liquid temperature	Material : LS,S2	-5~80°C (High temperature type is available up to 120°C)						
	Material : VV	-5~40°C						
Liquid pressure	Material : LS,S2	1.0MPa or less (Screwed type is up to 21.0MPa except symbol 10M0.)						
	Material : VV	0.3MPa or less						
Measuring accuracy	Material : LS,S2	Within $\pm 0.75\%$						
	Material : VV	Within $\pm 1.5\%$						
Standard connection	Material : LS,S2	Screwed type	Rc1/4		Rc1/2		-	
		Flange type	15A JIS10K RF		20A JIS10K RF		-	
	Material : VV	Screwed type	Rp1/2				Rp3/4	
		Flange type	15A JIS10K FF		20A JIS10K FF			
Material	Standard material symbol		LS				VV	
	Material : LS	Body : SCS14, Pressure proof cover : SCS14, Rotor : Special carbon or aluminum alloy						
	Material : S2 (1.0MPa or over)	Body : SUS316, Pressure proof cover : SUS316, Rotor : Special carbon or aluminum alloy						
	Material : VV	Body : PVC, Pressure proof cover : PVC, Rotor : PVC, Reducer : PVC						
		SCS14:Stainless steel casting; SUS316:Stainless steel;PVC:Poly vinyl chloride						
Material & Permissible Pressure		Standard connection		Material symbol		Permissible Pressure MPa		
		Screwed type		LS		1.0 (Liquid Temp.~120°C)		
				S2 (Except for volume symbol 10M0.)		21.0 (Liquid Temp.~120°C)		
				VV		0.3 (Liquid Temp.~40°C)		
		JIS10K Flange		LS/S2		1.0 (Liquid Temp.~120°C)		
VV				0.3 (Liquid Temp.~40°C)				

## Specification of pulse oscillating unit

Volume symbol		10M0	10L0	10LM	10LL	10LG	20P0	
Indication		Without						
Output	Pulse output	Number of output	1					
		Output assignment	Unscaled pulse					
		Kind of signal	Voltage no-contact or open drain					
			Voltage no-contact output : Signal level				Open drain : Voltage & current	
			H : Approx. equal to voltage of external power (at no load)				: 27VDC 30mA,	
		L : 0.5V or less (at no load)				Voltage at ON : 0.5V or less		
Output resistance : Approx. 2.3k $\Omega$ (Short-circuit protection resistance approx. 100 $\Omega$ )								
Signal logic		Positive or Negative logic						
		Positive logic : Logic 1 at H (Transister : OFF) Negative logic : Logic 1 at L (Transister : ON)						
Unit pulse		Without						
Unscaled pulse	Unit <sup>*1</sup>	0.1mL	0.5mL	0.9mL	2.1mL	6.6mL	6.7mL	
	Pulse width	Approx. 3.5ms						
Analogue output		Without						
Power		External power : 12~24VDC $\pm 10\%$						
Power consumption	At 12VDC	Approx. 12mA				Approx. 20mA		
	At 24VDC	Approx. 18mA				Approx. 25mA		
Ambient temperature		-10~60°C						
Explosion proof construction		-				Flameproof enclosure type <sup>**2</sup> (Exd II BT4X)		
Water proof		JIS C 0920 drip proof						
Casing material		Aluminum die casting						

※1 Output pulse unit of unscaled pulse shows nominal value output from this meter.

※2 Material symbol : LS,S2 Liquid temperature : -5~120°C, but in case of volume symbol 10M0, Material symbol : S2  
Liquid temperature : -5~60°C

#### 4. Flow range (Unit : L/h)

Material symbol : LS,S2 (Measuring accuracy ±0.75%)

Nominal size & Volume symbol	0.4mPa·s~	0.8mPa·s~	1mPa·s~	3mPa·s~	10mPa·s~	50~100mPa·s
	Gasoline	Water	Kerosene	Light oil	Heavy oil A	Heavy oil B,C
10M0	3~ 15	3~ 15	3~ 15	1.5~ 15	1~ 15	0.5~ 15
10L0	7~ 50	7~ 50	7~ 50	5~ 50	2.5~ 50	1~ 50
10LM	12~100	12~100	8~100	6.5~100	5~100	2~100
10LL	15~200	15~200	10~200	9~200	8~200	4~200
10LG	40~600	30~600	20~600	17.5~600	15~600	10~600

Material symbol : VV (Measuring accuracy ±1.5%)

Nominal size & Volume symbol	0.8mPa·s~	2mPa·s~	50~100mPa·s
10M0	4~ 15	3~ 15	2~ 15
10L0	8~ 50	6~ 50	4~ 50
10LM	15~100	12~100	6~100
10LL	20~200	15~200	10~200
10LG	40~600	30~600	20~600
20P0	400~2000	200~2000	150~2000

Note : When selecting a model of flow meter, please select it so that normal flow rate is 40~60% of its max. flow.

#### 5. Pressure loss

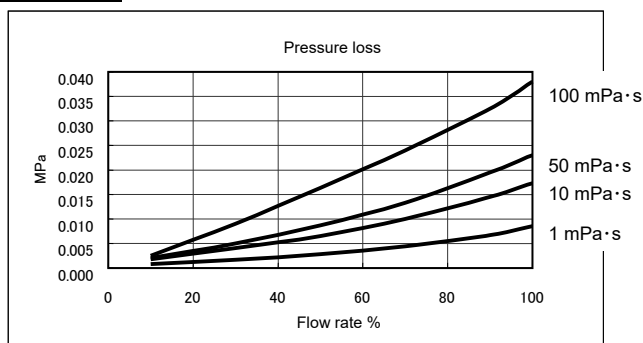

Nominal size symbol	Flow rate 100%
10M0	15L/h
10L0	50L/h
10LM	100L/h
10LL	200L/h
10LG	600L/h
20P0	2,000L/h

#### 6. Remote measurement system

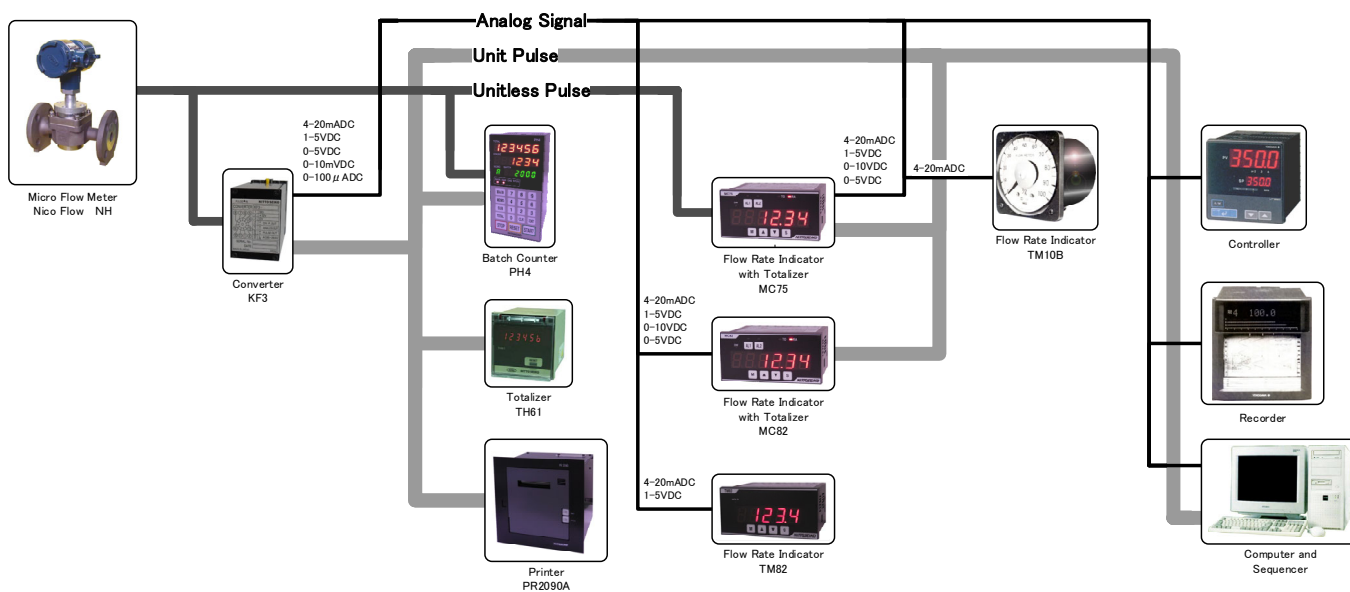

※The detailed input/output conditions vary depending on the specifications of the respective converter and receivers. Check with the specification sheet of the respective instruments.

7. External dimensions (Unit : mm)

Screwed type (Standard)

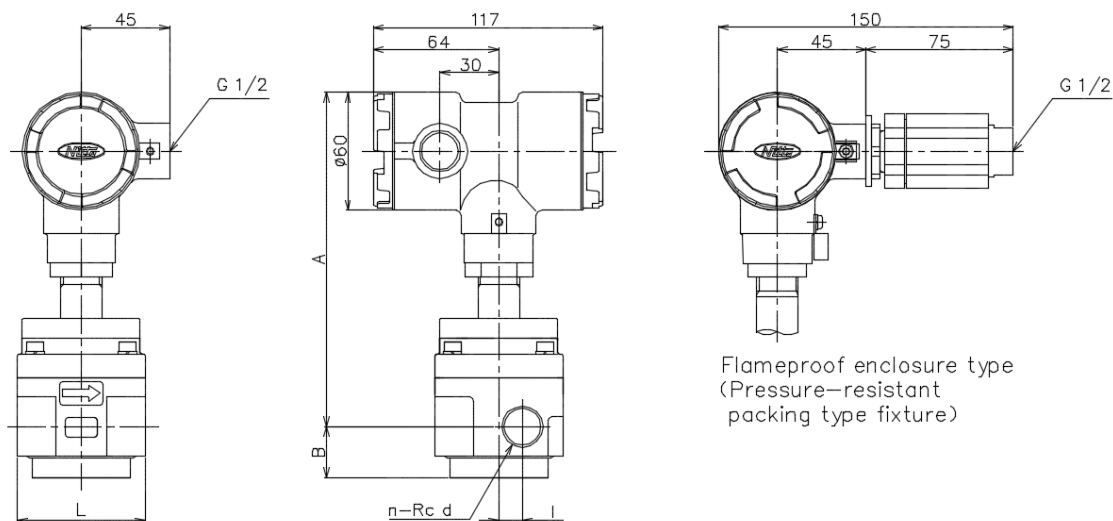

Flameproof enclosure type  
(Pressure-resistant  
packing type fixture)

Nominal size symbol	L	A	B	l	n	d(B)	Weight (kg)
10M0	60	163	24	7	2	1/4	1.9
10L0	60	164	24	7	2	1/4	1.9
10LM	65	170	26	12	2	1/2	2.4
10LL	65	170	26	12	2	1/2	2.3
10LG	80	178	26	19	2	1/2	3.2

This drawing show size of material LS.

In case of material symbol S2 and VV, appearance and size will be changed.

In case of clasification of temperature h,size is A+80mm.

Flange type (Standard)

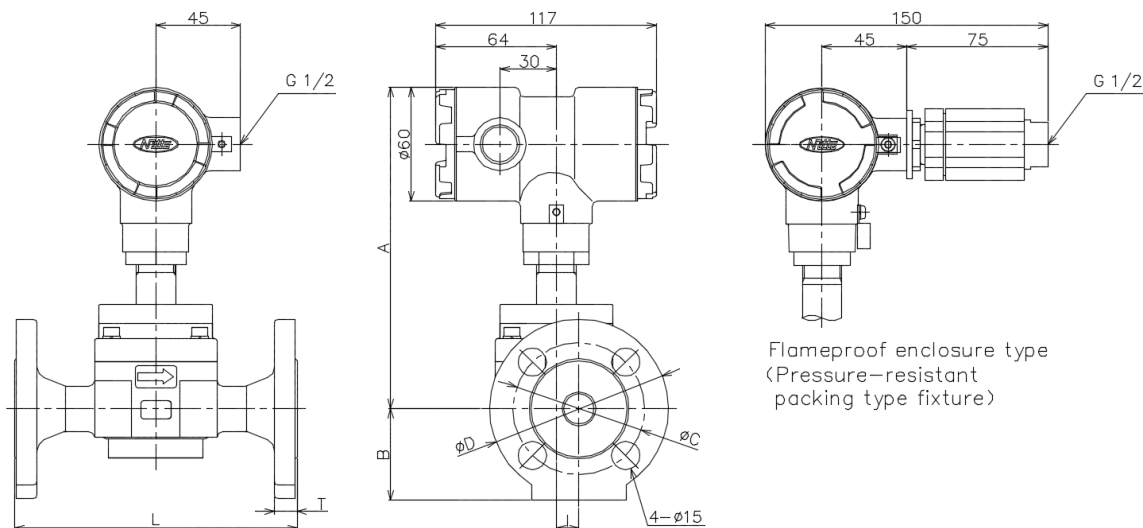

Flameproof enclosure type  
(Pressure-resistant  
packing type fixture)

Nominal size symbol	Nminal size	Flange standard	L	A	B	l	D	T	C	Weight (kg)
10M0	15	JIS10K	150	163	48.5	7	95	12	70	3.3
10L0			150	164	48.5	7	95	12	70	3.3
10LM			150	170	48.5	12	95	12	70	3.7
10LL			150	170	48.5	12	95	12	70	3.7
10LG	20	JIS10K	180	178	51	19	100	14	75	5.0

This drawing show size of material LS.

In case of material symbol S2 and VV, their appearance and dimensions are different from above.

In case of clasification of temperature h,size is A+80mm.

## 8. Terminal arrangement and wiring

### 8.1 Terminal arrangement

No.	Signal name
1	SIG Pulse output
2	+12~24V
3	0V

### 8.2 Wiring

- Wiring when using power source for pulser of the receiver

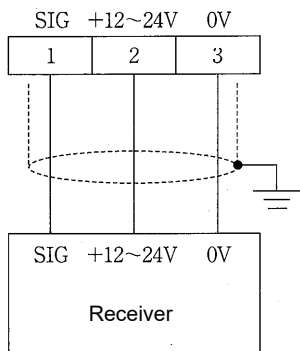

- Wiring when using power source for pulser except receiver

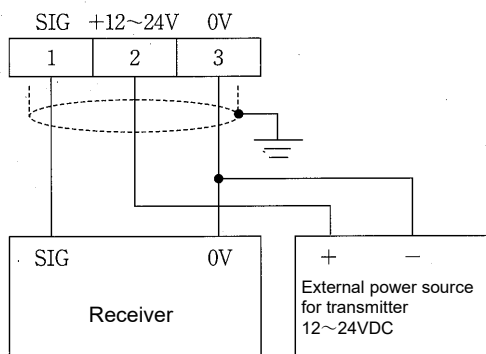

### 8.3 Pulse output circuit

Kind of output signal \ Switch	DS1-2	DS1-3
Voltage no-contact output	ON	OFF
Open drain output	OFF	ON

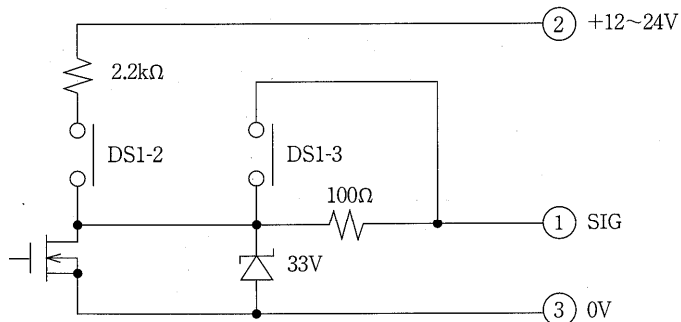

Note : Standard setting of pulse output is as follow.

Kind of signal Voltage no-contact output  
Signal logic Positive logic

## 9. Flame-proof packing type cable clamp

There are three kinds of flame-proof packing type cable clamp as shown below. Please use suitable one to meet with your using cable diameter. When placing order, please specify the model of flame-proof packing type cable clamp. (If there is no instruction, model HPN11R12 is equipped as standard.)

Model of flame-proof packing type cable clamp	Suitable cable dia. (mm)	Application
HPN11R8	6.0~8.0	Specified
HPN11R10	8.0~10.0	Specified
HPN11R12	10.0~12.0	Standard

## 10. Product code

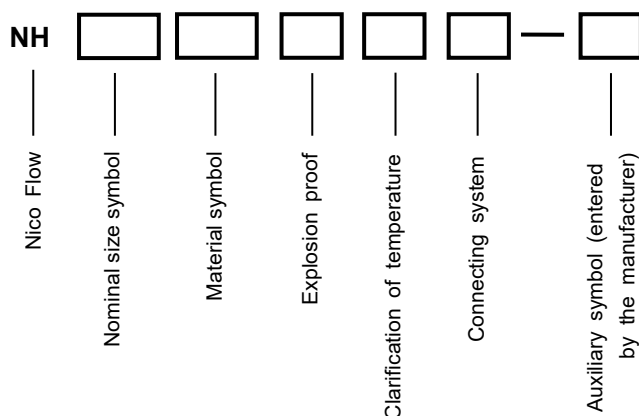

Type	Specification code	Description	10M0	10L0	10LM	10LL	10LG	20P0
NH		Nico Flow	●	●	●	●	●	●
Volume symbol	10M0	Flow rate 15L/h	●					
	10L0	Flow rate 50L/h		●				
	10LM	Flow rate 100L/h			●			
	10LL	Flow rate 200L/h				●		
	10LG	Flow rate 600L/h					●	
	20P0	Flow rate 2,000L/h						●
Material symbol	LS	Main body,pressure proof cover SCS14	●	●	●	●	●	×
	S2	Main body,pressure proof cover SUS316	○	○	○	○	○	×
	VV	Main body,pressure proof cover PVC	○	○	○	○	○	●
Explosion proof		Non-explosion proof	○	○	○	○	○	●
	X	Flameproof enclosure type	○	○	○	○	○	×
Classification of temperature	L	Allow able temperature : 80°C or less (For material symbol LS and S2) Non-explosion proof	○	○	○	○	○	×
		Allow able temperature : 60°C or less (For material symbol LS and S2) Flameproof enclosure type	○※1	○	○	○	○	×
		Allow able temperature : 40°C or less (For material symbol VV) Non-explosion proof	○	○	○	○	○	○
	H	Allow able temperature : 120°C or less (For material symbol LS and S2) Non-explosion proof	○	○	○	○	○	×
Allow able temperature : 120°C or less (For material symbol LS and S2) Flameproof enclosure type		×	○	○	○	○	×	
Connection	S	Screw ed type 1.0MPa or less	○	○	○	○	○	○
	T	Screw ed type 2.0MPa or less	×	○※2	○※2	○※2	○※2	×
	U	Screw ed type 3.0MPa or less	×	○※2	○※2	○※2	○※2	×
	W	Screw ed type 6.3MPa or less	×	○※2	○※2	○※2	○※2	×
	X	Screw ed type 21.0MPa or less	×	○※2	○※2	○※2	○※2	×
	F	Flange type	○	○	○	○	○	○

※1 Only material symbol S2 is available.

※2 Flameproof enclosure is unavailable.

## 11. Strainer

When the material symbol is LS (S2), install a strainer (200 mesh or over) without fail just before the flow meter. In case of material symbol VV, install a strainer (150 Mesh or over) just before the flow meter.

▼ The contents given here are subject to change without notice.

# NITTOSEIKO CO.,LTD.

30 Nogamibata, Nobu-Cho, Ayabe, Kyoto 623-0041, JAPAN

TEL : +81-773-43-3151(Domestic Operation)

+81-6-6105-5086(Global Sales Section)

FAX : +81-773-43-3155

E-mail:sales@nittoseiko.co.jp

https://www.nittoseiko.co.jp/en.html