

SLIDE VANE FLOW METER

SPECIFICATIONS

SSV20051 23.11

1. Outline

Slide vane flow meter is vane type positive displacement flow meter, creating high accuracy measurement and low pressure loss by decreasing rotation resistance. Solving the problem of noise, vibration and pulsation which are incidental to the large flow meters, it gives a stable performance. These meters are active in the fields of oil refinery, chemical, power and vessel.

2. Features

- Measurement in high accuracy is possible as rotor rotates at constant speed.
- Due to small revolution resistance, it gives large volume measurement with low pressure loss.
- It is less subject to temperature and viscosity, and possible the stable measurement with always high accuracy.
- Easy-to-read big indicator.
- Easy expansion with variety of pulse generators available for loading.

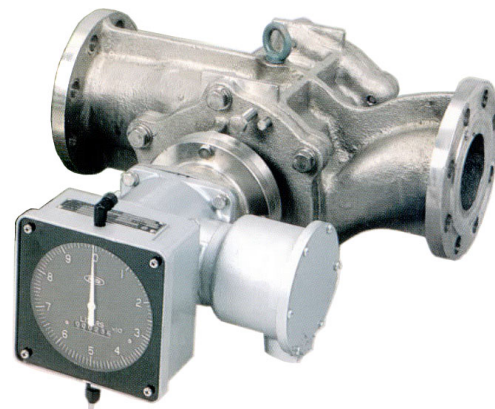

3. Specifications

Specifications of measuring unit

Nominal size & volume symbol	080	100		150		
	B0	A0	B0	A0		
Measured fluid	Chemical solutions, petroleum, water, etc.					
Nominal size	80A	100A		150A		
Liquid viscosity	0.4 ~ 500 mPa·s					
Liquid temperature	Normal temperature ~ 80°C (0 ~ 120°C (High temperature specification))					
Liquid pressure	2.0 MPa or under (By flange standards)					
Measuring accuracy	Within ±0.5% or within ±0.2% (Counter symbol A0 only and liquid temperature 60 °C. or lower)					
Standard connection	JIS10K, 20K, ANSI class 150 (For the details, see paragraph of "Process connection and face-to-face dimensions")					
Material	Symbol	Body	Measuring chamber	Rotor	Rotor shaft	Vane
	FF	FC200	FC200	AC3A	SK4	Special carbon
	S7	SCS13	SCS13	SCS13	SCS13	Special carbon
	FC200:Cast iron, SCS13:Stainless steel casting, AC3A:Corrosion-resistant aluminum, SK4:Tool steel					
Special specifications	Article approved for high-pressure gas service: Only material symbol S7 is manufacturable (only size 80A).					

Specifications of counter unit

Nominal size & volume symbol	080	100		150		
	B0	A0	B0	A0		
Indication	Direct-reading type (A0)	Pointer Dial plate	Dial unit	10 L		
			Volume/rev.	1 m ³		
		Total counter	Dial unit	x 1 m ³		
			No. of digits	6 (999,999 x 1m ³)		
	Digital zero-reset type (Z8)	Zero-reset counter	Dial unit	x 10 L		
			No. of digits	4 (9,999 x 100L)		
		Continuous total counter	Dial unit	x 100 L		
			No. of digits	7 (9,999,999 x 100L)		
	With instantaneous flow rate indicator (IO)	Pointer Dial plate	Dial unit	5 m ³ /h	10 m ³ /h	
			Full scale	100 m ³ /h	200 m ³ /h	
		Total counter	Dial unit	x 10 L		
			No. of digits	7 (9,999,999 x 10L)		
(Note) Select either one of (AO type, Z8 type, IO type) as type of indication.						
Output	Pulse output	Unit pulse	Type of signal	Either one of (1) voltage no-contact signal (high frequency type), or (2) reed switch contact signal.		
			Output unit	No-contact pulse output	See "No-contact pulse output" table.	
		Contact pulse output		See "Contact pulse output" table.		
	DA conversion pulse	No-contact pulse output possible.				
(Note) No simultaneous output of unit pulse and DA conversion pulse can be made.						
Analogue output		Direct output impossible. (DA converter required outside.)				

Power source	The following external power source is required for outputting voltage no-contact signals: High frequency type pulse generator: 6~26.4VDC	
Ambient temperature	0~60°C	
Explosion-protection	Flameproof enclosure type Exd II BT4	Either one of high frequency pulse generator or reed switch pulse generator.
Material	Aluminium die casting	

Output pulse unit table (Optional)

Non-contact output pulse unit table (○: High frequency type)

Nominal size & volume symbol	One rev. of pointer	Pulse unit						
		1mL/P	10mL/P	100mL/P	1L/P	10L/P	100L/P	1m³/p
080B0	100L	—	—	○	○	—	—	—
100A0	1m³	—	—	—	○	○	—	—
100B0	100L	—	—	○	○	—	—	—
150A0	1m³	—	—	—	○	○	—	—

Contact output pulse unit table (○: Reed switch)

Nominal size & volume symbol	One rev. of pointer	Pulse unit						
		1mL/P	10mL/P	100mL/P	1L/P	10L/P	100L/P	1m³/p
080B0	100L	—	—	—	○	○	○	—
100A0	1m³	—	—	—	—	○	○	○
100B0	100L	—	—	—	○	○	○	—
150A0	1m³	—	—	—	—	○	○	○

● High frequency pulse generator (Symbol: M)

Output signal : Voltage no-contact pulse
Approximate rectangular wave



H : 17V or more (10 kΩ load) (+V = 24VDC)
H : 8V or more (10 kΩ load) (+V = 12VDC)
L : 0.5V or less (10 kΩ load)

Output resistance : approx. 2.4kΩ

Output circuit

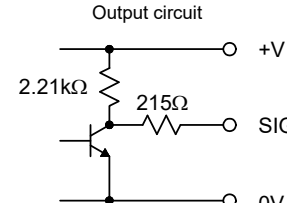

Max. generated pulse : 140P/sec
Power source : 6 – 26.4VDC
Power consumption : 23 mA or less (+V = 24VDC)
17 mA or less (+V = 12VDC)

● Reed switch pulse generator (Symbol: R)

Type	Output signal	Max. voltage	Max. current	Switch capacity	Contact resistance	Max. generated pulse
DRR-5	No-voltage contact pulse	200V AC·DC	1A	25W	0.06Ω	5P/sec
MR506	No-voltage contact pulse	50VDC	250mA	15W	0.1Ω	5P/sec

4. Flow range (m³ / h)

Accuracy: ± 0.5%

Nominal size & volume symbol	Working condition	Water (Normal temperature)	0.4mPa·s~	2mPa·s~	5mPa·s~	10mPa·s~	50~500mPa·s
080B0	Continuous	10~60	12~60	10~80	8~80	5~80	3~60
100A0	Intermittent	10~80	12~80	10~100	8~100	5~100	3~80
100B0	Continuous	20~120	24~120	20~160	16~160	10~160	6~120
150A0	Intermittent	20~160	24~160	20~200	16~200	10~200	6~150

Accuracy: ± 0.2% (Counter symbol A0 only and liquid temperature 60 °C. or lower)

Nominal size & volume symbol	Working condition	Water (Normal temperature)	0.4mPa·s~	2mPa·s~	5mPa·s~	10mPa·s~	50~500mPa·s
080B0	Continuous	20~60	24~60	20~80	16~80	10~80	6~60
100A0	Intermittent	20~80	24~80	20~100	16~100	10~100	6~80
100B0	Continuous	40~120	50~120	40~160	30~160	20~160	12~120
150A0	Intermittent	40~160	50~160	40~200	30~200	20~200	12~150

- Notes : 1. "Continuous" refers to a case where the daily operating time exceeds 8 hours, while "Intermittent" expresses a case where the daily operating time is no more than 8 hours.
2. When selecting a model of flow meter, please select it so that normal flow rate is 40~60% of its max. flow.

5. Pressure loss

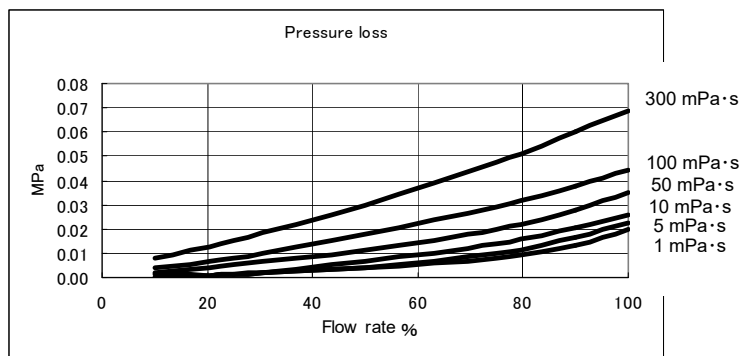

Flow rate 100%

Nominal size & volume symbol	Flow rate 100%
080B0, 100A0	100 m ³ /h
100B0, 150A0	200 m ³ /h

6. Process connection and face-to-face dimensions (mm)

Nominal size & volume symbol	Material symbol	JIS		ANSI
		10K	20K	Class150
080B0	F F	440	--	440
	D D	440	448	440
	S 7	440	448	452
	S 2	440	448	452
100A0	F F	440	--	440
	D D	440	448	440
	S 7	440	452	452
	S 2	440	452	452
100B0	F F	600	--	600
	D D	600	608	600
	S 7	600	--	612
	S 2	600	--	612
150A0	F F	600	--	600
	D D	600	612	600
	S 7	600	--	607
	S 2	600	--	607

Note) Process connection for which no numerical value is indicated on the table cannot be manufactured.

7. Piping method

- Install a strainer on the inlet side of the flow meter without fail. To avoid outflow to the downstream side due to damage of internal component parts, install a strainer also on the outlet side of the flow meter. (Note) The standard mesh of the strainer element is 60 meshes.
- Install a bypass piping. In designing this bypass piping, take account of protection of the inner elements of the flow meter against the influences of flushing in the early period of operation or discharge of air in the piping as well as ease of maintenance and inspection work.
- Secure a space necessary for inspection, disassembling, etc. of the flow meter in the piping arrangement. Especially, secure a space for enabling disassembling of the measuring chamber of the flow meter.

Examples of piping installation

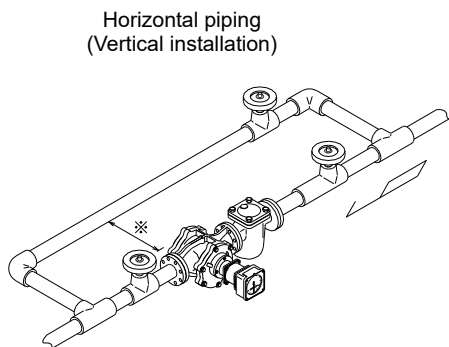

Vertical piping

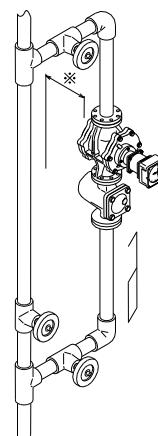

The mark ※ indicates a space necessary for disassembling and inspection. Install the piping in a way to secure a dimension no small than the figures indicated on the table below.

Unit (mm)		
Nominal size & volume symbol	080B 100A	100B 150A
※Dimension	120	160

Note) Flow direction top to bottom is unavailable.

8. Remote measurement system

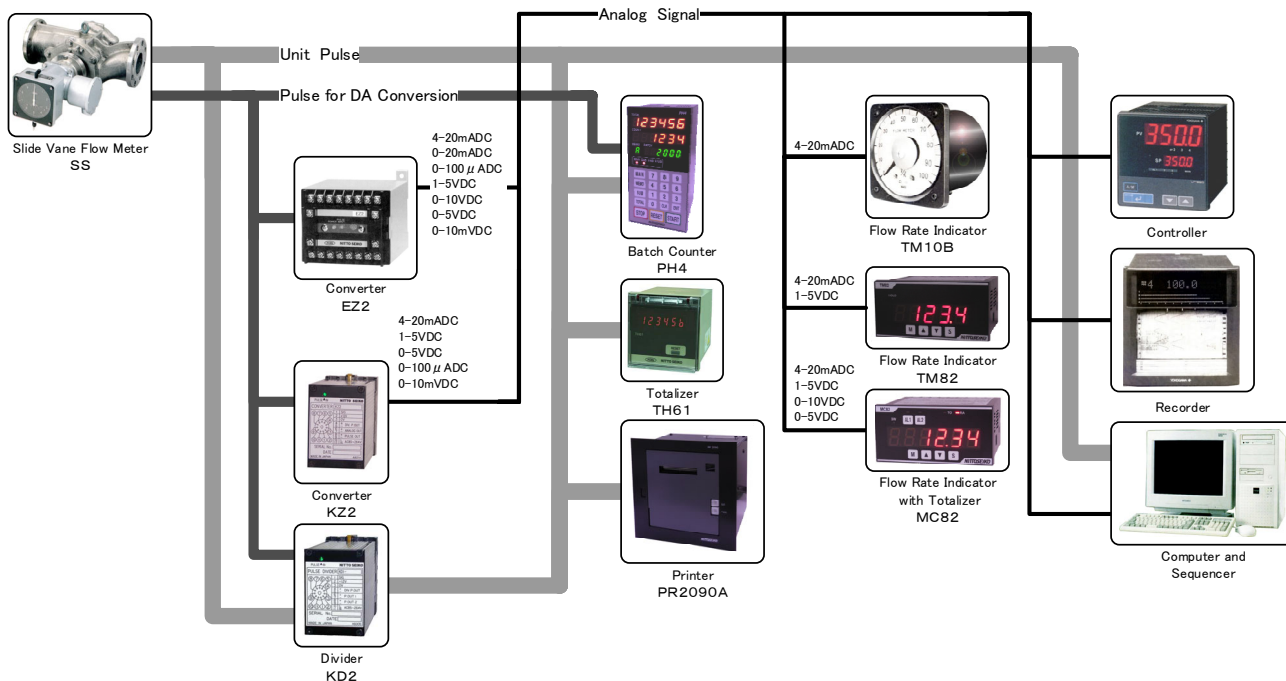

※The detailed input/output conditions vary depending on the specifications of the respective converter and receivers. Check with the specification sheet of the respective instruments.

9. External dimensions (mm)

● Direct-reading type

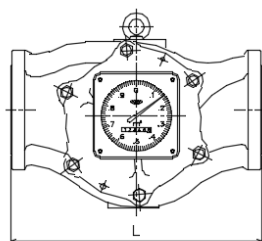

(A0 Register)

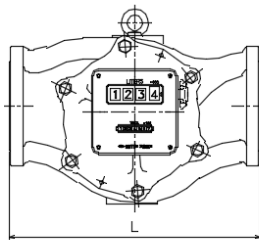

(Z8 Register)

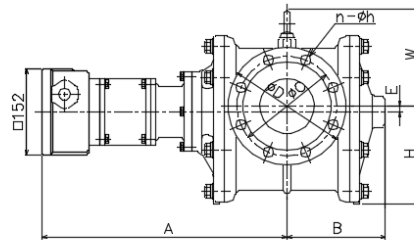

● Pulse generator type

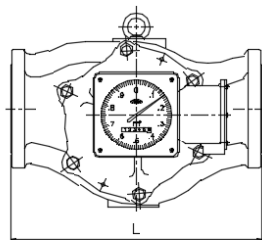

(A0 Register)

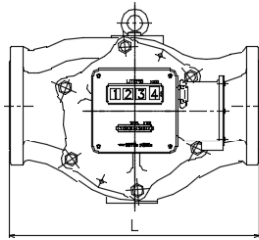

(Z8 Register)

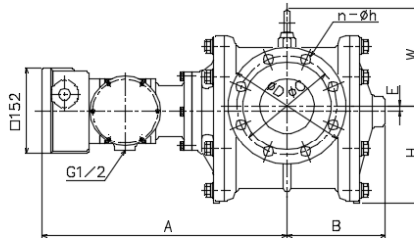

● Explosion-protection type

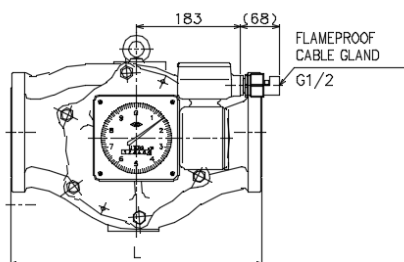

(A0 Register)

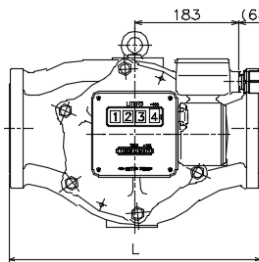

(Z8 Register)

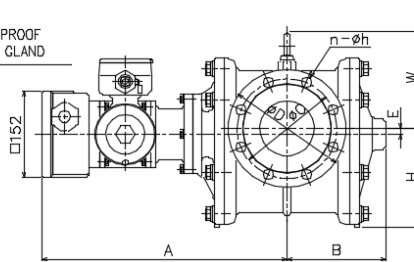

Nominal size & volume symbol	Nominal size	Flange standard	L			A	B	W	H	E	D	C	n	h	Weight (kg)
			FC	FCD	SCS										
080B0	80	JIS10K	440	440	440	431	173	167	166	10	185	150	8	19	74
		JIS20K	-	448	448						200	160	8	23	76
100A0	100	JIS10K	440	440	440	431	173	171	173	10	210	175	8	19	76
		JIS20K	-	448	452						225	185	8	23	78
100B0	100	JIS10K	600	600	600	495	234	192	180	0	210	175	8	19	115
		JIS20K	-	608	-						225	185	8	23	117
150A0	150	JIS10K	600	600	600	495	234	192	180	0	280	240	8	23	127
		JIS20K	-	612	-						305	260	12	25	132

Note) Shown weight is for the counter symbol (A0) with material code FF (JIS 10K) and DD (JIS 20K). Add 2kg for signal output type, and add 5kg for explosion proof type.

● Instantaneous flow rate indicator type

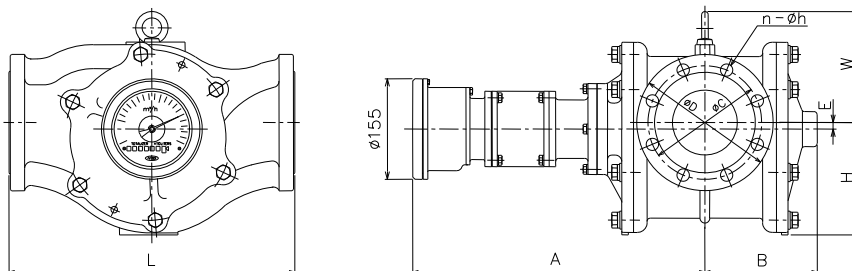

Nominal size & volume symbol	Nominal size	Flange standard	L			A	B	W	H	E	D	C	n	h	Weight (kg)
			FC	FCD	SCS										
080B0	80	JIS10K	440	440	440	453	173	167	166	10	185	150	8	19	75
		JIS20K	-	448	448						200	160	8	23	77
100A0	100	JIS10K	440	440	440	453	173	171	173	10	210	175	8	19	77
		JIS20K	-	448	452						225	185	8	23	79
100B0	100	JIS10K	600	600	600	517	234	192	180	0	210	175	8	19	116
		JIS20K	-	608	-						225	185	8	23	118
150A0	150	JIS10K	600	600	600	517	234	192	180	0	280	240	8	23	128
		JIS20K	-	612	-						305	260	12	25	133

- Note) 1. In case of single stage radiating fin, size is A+100mm, and weight is +2kg.
 2. Shown weight is for material code FF (JIS 10K) and DD (JIS 20K). Add 2kg for signal output type, and add 5kg for explosion proof type.

10. Products code

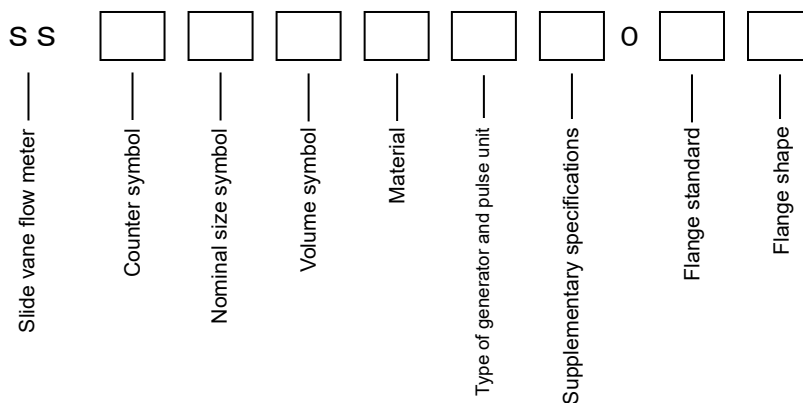

●: Standard; ○: Manufacturable; ×: Non-manufacturable

Type	Specification code	Specifications	080B0	100A0	100B0	150A0
SS		Slide vane flow meter	●	●	●	●
Counter symbol	A0	Pointer and direct-reading type	●	●	●	●
	Z8	Digital zero-reset and direct-reading type	●	●	●	●
	I0	With direct-reading instantaneous flow indicator	○	○	○	○
	CN	Pneumatic batch counter type (80B-100A only)	○	○	×	×
Nominal size symbol	080	80mm	●			
	100	100mm		●	●	
	150	150mm				●
Volume symbol	A0	Volume small	×	●	×	●
	B0	Volume large	●	×	●	×
Material symbol	FF	Main body: FC200, Measuring chamber: FC200, Rotor: AC3A, Rotor shaft: SK4, Vane: Special Carbon, Operating pressure: 1.0 MPa	●	●	●	●
	S7	Main body: SCS13, Measuring chamber: SCS13, Rotor: SCS13, Rotor shaft: SCS13, Vane: Special Carbon, Operating pressure: 1.0 MPa, 2.0 MPa	●	●	●	●
	FC: Cast iron, SCS13: Stainless steel casting; AC3A: Corrosion-resistant aluminum, SK4: Tool steel					
Type of generator and pulse unit <small>Note) The pulse units available for output are restricted depending on: (1) pointer specifications, (2) type of generator. Refer to "Output Pulse Unit Table".</small>	12	Without pulse output	●	●	●	●
	R4	Reed switch (contact) pulse 1L/p	(○)	(○)	×	×
	R5	Reed switch (contact) pulse 10L/p	○	○	○	○
	R6	Reed switch (contact) pulse 100L/p	○	○	○	○
	R7	Reed switch (contact) pulse 1m3/p	○	○	○	○
	M3	High frequency (no-contact) pulse 0.1L/p	(○)	(○)	×	×
	M4	High frequency (no-contact) pulse 1L/p	○	○	○	○
	M5	High frequency (no-contact) pulse 10L/p	○	○	○	○
	MD	High frequency (no-contact) pulse DA conversion pulse	○	○	○	○
XX	Other	○	○	○	○	
Supplementary specifications	345	Non-explosion proof & without radiating fins	●	●	●	●
	X00	Flameproof enclosure type	○	○	○	○
Flange standard	010	JIS 10K	●	●	●	●
	020	JIS 20K	○	○	○	○
	AS1	ANSI class 150	○	○	○	○
Flange shape	R	RF flange	●	●	●	●
	F	FF flange	○	○	○	○

11. Strainer

To avoid a flow meter trouble caused by foreign matter in a liquid coming into the flow meter, it is necessary to install a strainer shortly before or as near as before the upstream side of the flow meter.

◆◆◆ Matters to be specified at the time of ordering ◆◆◆

1. Type and specification code
2. Name of measured liquid, viscosity, temperature
3. Flow direction of fluid, mounting position

▼ The contents given here are subject to change without notice.

NITTOSEIKO CO., LTD.

30 Nogamibata, Nobu-Cho, Ayabe, Kyoto 623-0041, JAPAN
 TEL : +81-773-43-3151(Domestic Operation)
 +81-6-6105-5086(Global Sales Section)
 FAX : +81-773-43-3155
 E-mail:sales@nittoseiko.co.jp
<https://www.nittoseiko.co.jp/en.html>